

KCP COUPLINGS

www.koreacoupling.co.kr

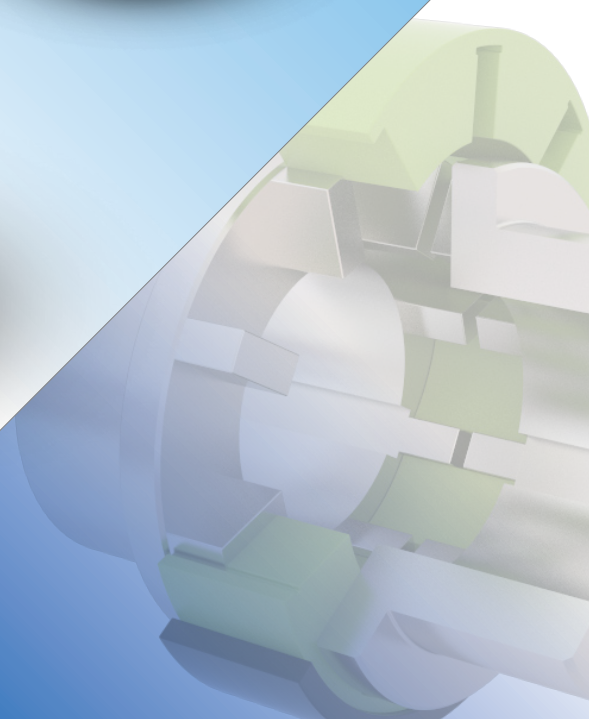
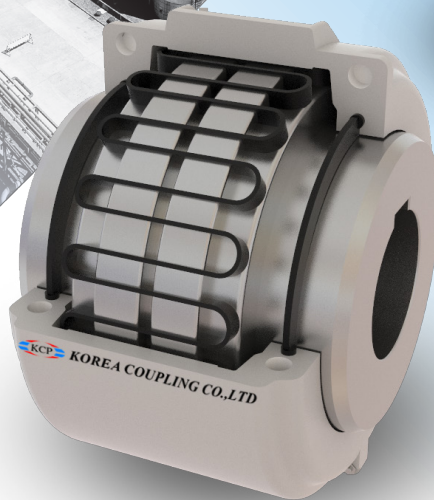
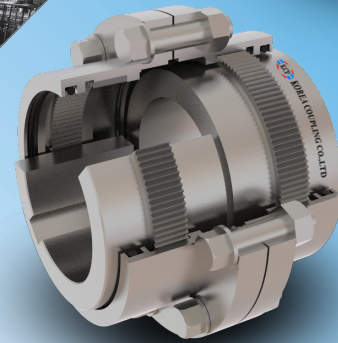

KOREA COUPLING CO., LTD

Korea Coupling Co., Ltd is specialized and global market leader of power transmission components manufacturer from Korea since 1992.

We have been supplying high quality and valued products to various industries such as coal mining, paper, food industries, and petro chemical, steel, and cement mills.

Korea Coupling's products are mainly used for hydraulic machineries, pumps, blower fans, conveyors, and cranes as well as general power driven industrial equipments.

The management philosophy of Korea Coupling is creating and serving the best engineered power transmission products in the duration to our valued clients and new global and domestic market with supporting a higher standard of performance.

We consistently do our utmost to produce and improve the best value of our products and services. Your deserved patronage and great relationships along with closer contacts will be greatly appreciated.

Wishing you everlasting prosperity and significant cooperation.

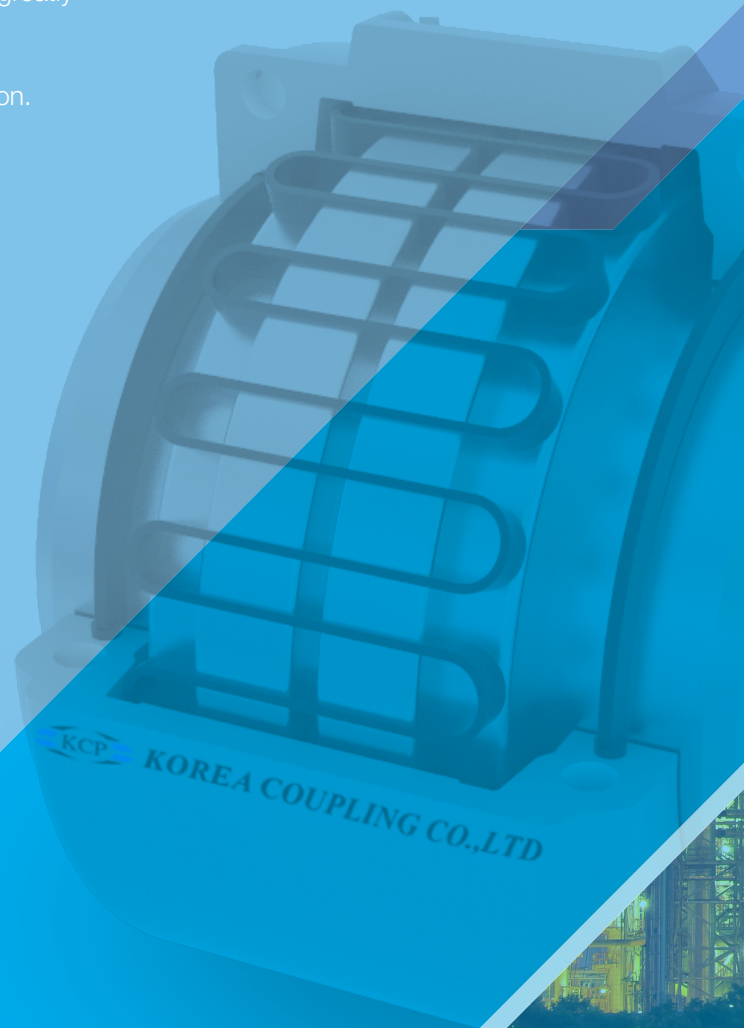
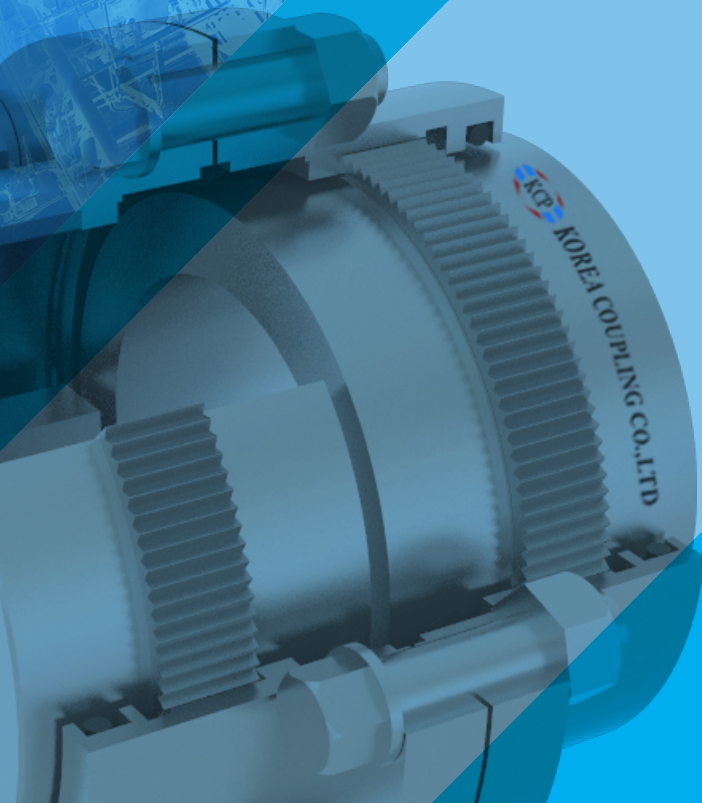



Table of Contents

Description	Page
Coupling Selection	04
Service Factors	05
Taper Grid Couplings	08
Gear Couplings	23
Disc Flexible Couplings	40
Tire Couplings	52
KW Flex Couplings	58
Max Dynamic & Field Couplings	63
Nylon Coupling	69
Wire Drum Coupling	71
Flange Flexible Couplings	73
Universal Joints	78
Reference	85

Coupling Selection

How to Select

Standard Selection

The Standard Selection may be used for engine driven, motor, or turbine applications. The following information is required:

- Application or equipment type (motor to pump, reducer to conveyor, etc.)
- Shaft diameters (mm)
- Gaps between shafts (mm)
- Speed (RPM)
- Horsepower or torque (Nm)

1. Rating : Determine system torque. Torque is calculated as follows :

$$\text{I . Torque (Nm)} = \frac{\text{kW} \times 9,550}{\text{RPM}} \quad \text{II . Torque (Kg.m)} = \frac{\text{kW} \times 974}{\text{RPM}}$$

2. Service Factor : Determine appropriate service factor from page. 5-6

3. Minimum Coupling Rating : Determine the required minimum coupling rating as follows :

$$\text{Minimum Coupling Rating} = \text{Service Factor} \times \text{Torque (Nm)}$$

4. Type : Select the appropriate coupling type

5. Size : Trace the Torque column to find the value that is equal or greater than value from Step 3.

6. Check : Check speed (RPM), bore, gap and dimensions.

Formula Selection

The Standard Selection should be used for most coupling selections.

The Formula Selection procedure below should be used for:

- High Peak Loads.
- Brake Applications (Brake disc or brake wheel is an integral part of coupling)

Using the Formula Selection and providing system peak torque and frequency, duty cycle, and brake torque rating will allow for a more refined selection.

1. High Peak Loads : Use formula A or B for applications which involve motors with higher than normal torque characteristics. Applications should also be those with intermittent operations, including shock loading, inertia effects due to starting and stopping, system-induced repetitive high peak torques. System Peak Torque is the maximum torque that can exist in the system. Select a coupling with a Torque Rating equal or greater than the Selection Torque calculated below:

A. Non-Reversing High Peak Torque : Selection torque (Nm) = System Peak Torque or

$$\text{System Torque (Nm)} = \frac{\text{System peak kW} \times 9549}{\text{RPM}}$$

B. Reversing High Peak Torque : Selection Torque (Nm) = 2 x System Peak Torque or

$$\text{System Torque (Nm)} = \frac{2 \times \text{Peak kW} \times 9549}{\text{RPM}}$$

2. Brake Applications : If the torque rating of the brake exceeds the motor torque, use brake rating as blow :

$$\text{Selection Torque (Nm)} = \text{Brake Torque Rating} \times \text{Service Factor}$$

Service Factors

Service Factors for Operation of Drive System

Application	Service Factor
AERATOR	2.0
AGITATORS	
Vertical and Horizontal Scenv, Propeller, Paddle	1.0
BARGE HAUL PULLER	1.5
BLOWERS	
Centrifugal	1.0
Lobe or Vane	1.25
CAR DUMPERS	2.5
CAR PULLERS	1.5
CLARIFIER or CLASSIFIER	1.0
COMPRESSORS	
Centrifugal	1.0
Rotary, Lobe or Vane	1.25
Rotary, Screw	1.0
With Flywheel and Gear between Compressor and Prime Mover	
1 Cylinder, single acting	3.0
1 Cylinder, double acting	3.0
2 Cylinders, single acting	3.0
2 Cylinders, double acting	3.0
3 Cylinders, single acting	3.0
3 Cylinders, double acting	2.0
4 or more cylinders, single acting	1.75
4 or more cylinders, double acting	1.75
CONVEYORS	
Apron, Assembly, Belt, Chain, Flight, Screw	1.0
Bucket	1.25
Live Roll, Shaker and Reciprocating	3.0
CRANES and HOIST	
Main Hoist	1.75
Skip Hoist	1.75
Slope	1.5
Bridge, Travel or Trolley	1.75
DYNAMOMETER	1.0
ELEVATORS	
Bucket, Centrifugal Discharge	1.25
Gravity Discharge	1.25
EXCITER, GENERATOR	1.0
EXTRUDER, PLASTIC	1.5
FANS	
Centrifugal	1.0
Cooling Tower	2.0
Forced Draft-Across the Line start	1.5
Forced Draft Motor driven thru fluid or electric slip clutch	1.0
Gas Recirculating	1.5
Induced Draft with damper control or blade cleaner	1.25
Induced Draft without controls	2.0
FEEDERS	
Apron, Belt, Disc, Screw	1.0
Reciprocating	2.5
GENERATORS	
Even Load	1.0
Hoist or Railway Service	1.5
Welder Load	2.0
GENERATORS	
Even Load	1.0

Application	Service Factor
Hoist or Railway Service	1.5
Welder Load	2.0
HAMMERMILL	1.75
LAUNDRY WASHER or TUMBLER	2.0
LINE SHAFTS	
Any Processing Machinery	1.5
MACHINE TOOLS	
Auxiliary and Traverse Drive	1.0
Bending Roll, Notching Press, Punch Press, Planer, Plate Reversing	1.75
Main Drive	1.5
METAL FORMING MACHINES	
Continous Caster	1.75
Draw Bench Carriage and Main Drive	2.0
Extruder	2.0
Farming Machine and Forming Mills	2.0
Slitters	1.0
Wire Drawing or Flattening	1.75
Wire Winder	1.5
Coilers and Uncoilers	1.5
MIXERS	
Concrete	1.75
Muller	1.5
PRESS, PRINTING	1.5
PUG MILL	1.75
PULVERIZERS	
Hammermil and Hog	1.75
Roller	1.5
PUMPS	
Boiler Feed	1.5
Centrifugal-Constant Speed	1.0
Frequent Speed Changes under Load	1.25
Descaling with accumulators	1.25
Gear, Rotary, or Vane	1.25
Reciprocating, Plunger Piston	
1 Cylinder, single or double acting	3.0
2 Cylinders, single acting	2.0
2 Cylinders, double acting	1.75
3 or more cylinders	1.5
Screw Pump, Progressing Cavity	1.25
Vacuum Pump	1.25
SCREENS	
Air Washing	1.0
Grizzly	2.0
Rotary Coal or Sand	1.5
Vibrating	2.5
Water	1.0
STEERING GEAR	1.0
STOKER	1.0
TIRE SHREDDER	1.5
TUMBLING BARREL	1.75
WINCH, MANEUVERING	
Dredge, Marine	1.5
WINDLASS	1.5
WOODWORKING MACHINERY	1.0

Service Factors and Reference

Service Factors for Operation of Drive System

Industry	Service Factor
AGGREGATE PROCESSING, CEMENT, MINING KILNS; TUBE, ROD and MILLS	
Direct or on L.S. shaft of Reducer, with final drive Machined Spur Gears	2.0
Single Helical or Herringbone Gears	1.75
Crushers, Ore or Stone	2.5
Dryer, Rotary	1.75
Grizzly	2.0
Hammermill or Hog	1.75
Tumbling Mill or Barrel	1.75
BREWING and DISTILLING	
Bottle and Can Filling Machines	1.0
Brew Kettle	1.0
Cookers, Continuous Duty	1.25
Lauter Tub	1.5
Mash Tub	1.25
Scale Hopper, Frequent Peaks	1.75
CLAY WORKING INDUSTRY	
Brick Press, Briquette Machine, Clay Working Machine, Pug Mill	1.75
DREDGES	
Cable Reel	1.75
Conveyors	1.25
Cutter head, Jig Drive	2.0
Maneuvering Winch	1.5
Pumps (Uniform load)	1.5
Screen Drive, Stacker	1.75
Utility Winch	1.5
FOOD INDUSTRY	
Beet Slicer	1.75
Botting, Can Filling Machine	1.0
Cereal Cooker	1.25
Dough Mixer, Meat Grinder	1.75
LUMBER	
Band Resaw	1.5
Circular Resaw, Cut-off	1.75
Edger, Head Rig, Hog	2.0
Log Haul	2.0
Planer	1.75
Rolls, Non-Reversing	1.25
Rolls, Reversing	2.0
Sawdust Conveyor	1.25
Slab Conveyour	1.75
Sorting Table	1.5
Trimmer	1.75
METAL ROLLING MILLS	
Coilers (Up or Down) Cold Mills only	1.5
Coilers (Up or Down) Hot Mills only	2.0
Coke Plants	
Pusher Ram Drive	2.5
Door Opener	2.0
Pusher or Larry Car Traction Drive	3.0
Continuous Caster	1.75
Colling Beds	1.5
Drawbench	2.0
Feed Rolls-Blooming Mills	3.0
Furnace Pushers	2.0
Hot and Cold Saws	2.0
Ingot Cars	2.0
Manipulators	3.0
Mill Tables	
Roughing Breakdown Mills	3.0
Hot Bed or Transfer, non-reversing	1.5
Runout, reversing	3.0
Runout, non-reversing, non-plugging	2.0
Reel Drives	1.75
Screwdown	2.0
Seamless Tube Mills	
Piercer	3.0
Thrust Block	2.0
Tube Conveyor Rolls	2.0
Reeler	2.0
Kick Out	2.0
Sideguards	3.0

Industry	Service Factor
Slitters, Steel Mill only	1.75
Lift	1.0
Travel	2.0
Straighteners	2.0
Unscramblers (Billet Bundle Busters)	2.0
Wire Drawing Machinery	1.75
OIL INDUSTRY	
Chiller	1.25
Oilwell Pumping (not over 150% peak torque)	2.0
Paraffin Filter Press	1.5
Rotary Kiln	2.0
PAPER MILLS	
Barker Auxiliary, Hydraulic	2.0
Barker, Mechanical	2.0
Barking Drum	
L.S. shaft of reducer with final drive-Helical or Herringbone Gear	2.0
Machined Spur Gear	2.5
Cast Tooth Spur Gear	3.0
Beater & Pulper	1.75
Bleachers, Coaters	1.0
Calender & Super Calender	1.75
Chipper	2.5
Converting Machine	1.25
Couch	1.75
Cutter, Felt Whipper	2.0
Dryer	1.75
Cylinder	1.75
Felt Stretcher	1.25
Fourdrinier	1.75
Jordan	2.0
Log Haul	2.0
Line Shaft	1.5
Press	1.75
Pulp Grinder	1.75
Reel, Rewinder, Winder	1.5
Stock Chest, Washer, Thickener	1.5
Stock Pumps, Centrifugal	
Constant Speed	1.0
Frequent Speed Changes Under load	1.25
Suction Roll	1.75
Vacuum Pumps	1.25
RUBBER INDUSTRY	
Calender	2.0
Cracker, Plasticator	2.5
Extruder	1.75
Intensive or Banbury Mixer	2.5
Mixing Mill, Refiner or Sheeter	
One or two in line	2.5
Three or four in line	2.0
Five or more in line	1.75
Tire Building Machine	2.5
Tire & Tube Press Opener (Peak Torque)	1.0
Tuber, Strainer, Pelletizer	1.75
Warming Mill	
One or two Mills in line	2.0
Three or more Mills in line	1.75
Washer	2.5
SEWAGE DISPOSAL EQUIPMENT	
Bar Screen, Chemical feeders, Collectors, Dewatering Screen, Grit Collector	1.0
SUGAR INDUSTRY	
Cane Carrier & Leveler	1.75
Cane Knife & Crusher	2.0
Mill Stands, Turbine Driver with all Helical or Herringbone, or Spur Gears with any Prime Mover	1.75
TEXTILE INDUSTRY	
Batcher	1.25
Calender, Card Machine	1.5
Cloth Finishing Machine	1.5
Dry Can, Loom	1.5
Dyeing Machinery	1.25
Mangle, Napper, Soaper	1.25
Spinner, Tenter Frame, Winder	1.5

Service Factors







Standard Selection

Service Factors for engine drives are required for applications where good flywheel regulation prevents torque fluctuations greater than $\pm 20\%$. For drives where torque fluctuations are greater or where the operation is near a serious critical or torsional vibration, a mass elastic study is necessary.

Number of Cylinders	4 or 5					6 or more				
Service Factor	1.5	1.75	2	2.25	2.5	1.5	1.75	2	2.25	2.5
Engine Service Factor	2.5	2.75	3	3.25	3.5	2.5	2.75	3	3.25	3.5

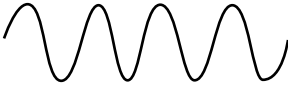
To use Engine Drive Service Factors, first determine application Service Factor from page 5-6. When Service Factor is greater than 2.0, or where 1, 2 or 3 cylinder engines are involved, refer complete application details to Korea Coupling for engineering review.

Service Factors are a guide, based on experience, of the ratio between coupling catalogue rating and system characteristics. The system characteristics are best measured with a torque meter.

Torque Demands Driven Machine	Typical applications for Driven Equipment	Typical Service Factor
	Constant torque such as Centrifugal Pumps, Blowers and Compressors.	1.0
	Continuous duty with some torque variations including Plastic Extruders, Forced Draft Fans.	1.5
	Light shock loads from Metal Extruders, Cooling Towers, Cane Knife, Log Haul.	2.0
	Moderate shock loading as expected from a Car Dumper, Stone Crusher, Vibrating Screen.	2.5
	Heavy shock load with some negative torques from Roughing Mills, Reciprocating Pumps, Compressors, Reversing Runout Talbes.	3.0
	Applications like Reciprocating Compressors with frequent torque reversals, which do not necessarily cause reverse rotations.	Refer to KCP

Taper Grid Couplings

Horizontal Split Cover Type

- Best Choice for limited spaces
- Allows easy access to the grid spring
- Suitable for reversing applications
- Light weight, die-cast aluminum grid cover



Vertical Split Cover Type

- Best choice for high operating speeds
- Allows easy access to the grid spring
- Steel grid cover for strength

KCP Tapered Grid Couplings are shaft-to-shaft couplings that are of compact size, yet can handle torque capacity due to their high strength hardened alloy steel construction.

The tapered grids are designed with a trapezoidal cross section and are tempered for spring hardness. Through a high-precision operation called shot peening, the surface molecules are compressed by high-velocity steel micro beads. The compression of the molecules results in dramatic increase in strength rating and provides reserve strength for a longer part life.

The tapered grids are accessible through the unit's removable cover. It is extremely easy to fit the trapezoidal grids into the slots of the hub, compared to fitting rectangular grids. There is no need for the equipment to be moved (hence downtime) so that couplings can be installed.

Due to their compact size, the tapered grids can simply be placed directly in the slots of the hub. Finally, the practical split cover can be placed using standard tools.

Protection Against Shaft Misalignment

The tapered grids are free to rock, pivot, and float within the hub teeth. This provides generous capacity for misalignment without producing the detrimental side loads on the bearings that are often created when couplings are misaligned.

Protection Against Shock & Vibratory loads

KCP Tapered Grid Couplings are able to deflect torsionally when subjected to normal shock or vibratory loads, so they are able to handle changing load conditions.

The system truly is a shock absorber for rotary motion, relying on the predictable resilience of the grid for torsional flexibility. The tapered grids "tune" the drive system. Due to their spring hardness, the grids absorb impact by spreading the impact energy over time. The grids can also damp vibration and reduce the peak or shock loads experienced by the rest of the system.

Taper Grid Coupling Types

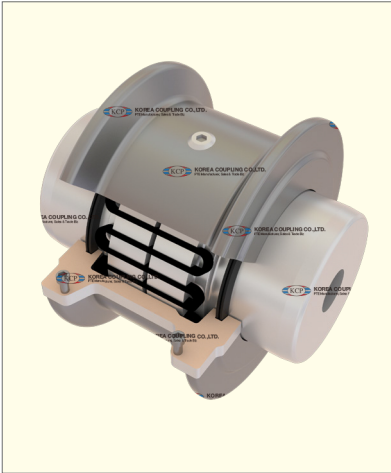

T10 Type



T10 Type (Large)



T20 Type



T31 Type (Full Spacer)



T35 Type (Half Spacer)



T50 Type (Spacer)

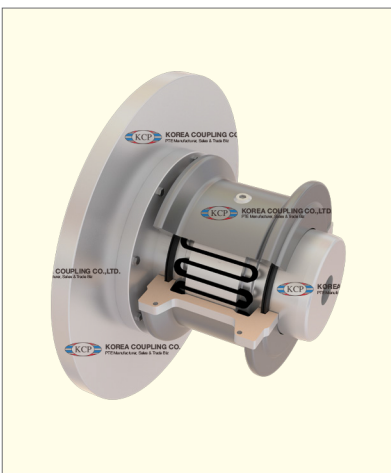

T63 Type

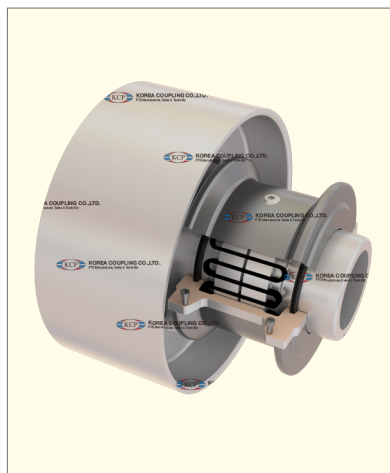

KBW Type



T10 & G82 Type (Floating Shaft)

Vibration & Shock

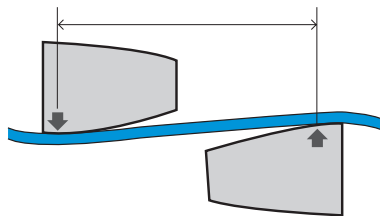
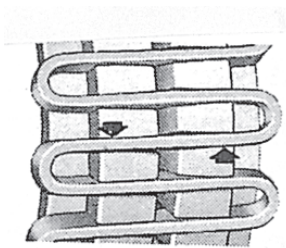
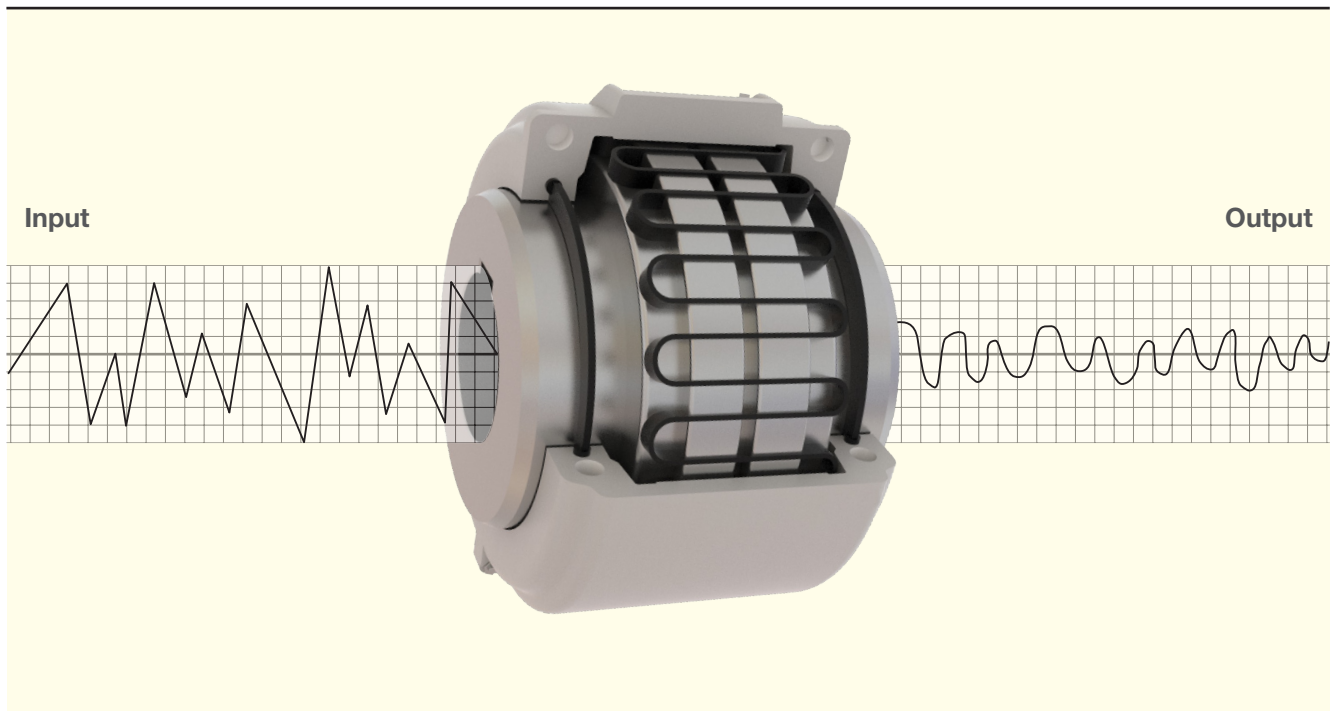

Light Load

The grid contacts near the outer edges of the hub teeth. A long span between the points of contact remains free to flex under load.

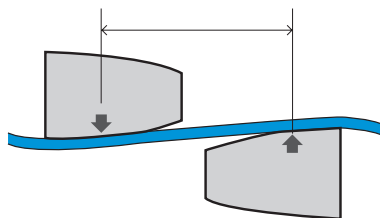
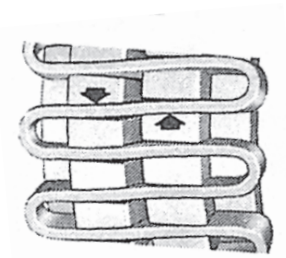

Normal Load

As the load increases, the distance between the contact points on the hub teeth is shortened, but a free span still remains to cushion the load.

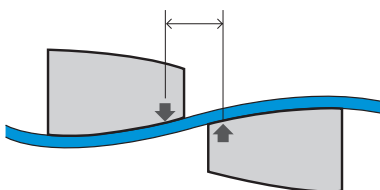
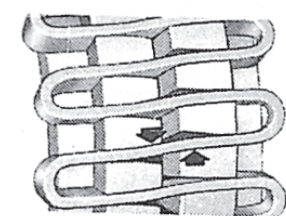

Shock Load

The coupling is flexible within its rated capacity. Under extreme overloads, the grid bears fully on the hub teeth and transmits full load directly.

T10 Type

Close Coupled Horizontal Split Aluminium Cover

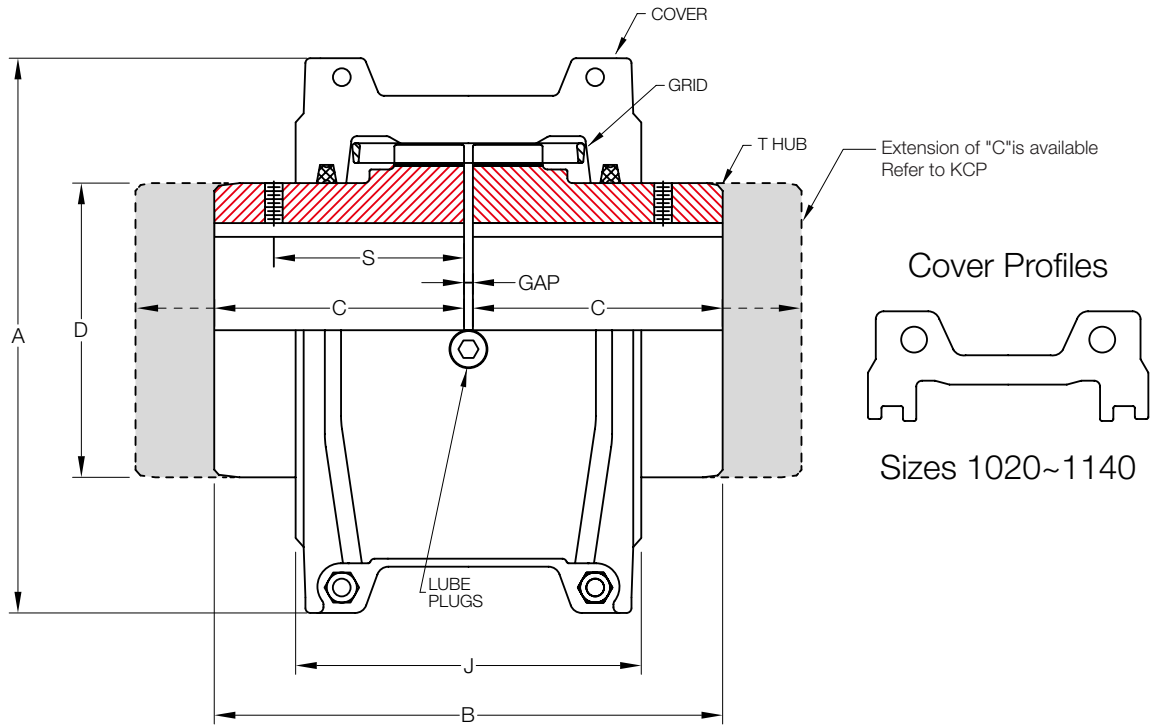

Size	Torque Rating (Nm)	Allow Speed RPM	Max Bore (mm)	Min Bore (mm)	Cplg Weight (Kg)	Lube Weight (Kg)	Dimensions (Millimeters)						Size	
							A	B	C	D	J	S		GAP
1020	52	4,500	28	13	1.92	0.0272	101.0	98.2	47.6	39.7	67.8	39.1	3	1020
1030	149	4,500	35	13	2.58	0.0408	109.0	98.2	47.6	49.2	71.9	39.1	3	1030
1040	249	4,500	43	13	3.34	0.0544	116.0	104.6	50.8	57.2	72.0	40.1	3	1040
1050	435	4,500	50	13	5.44	0.0680	137.8	123.6	60.3	66.7	81.6	44.7	3	1050
1060	684	4,350	56	20	7.44	0.0862	147.0	130.0	63.5	76.2	97.9	52.3	3	1060
1070	994	4,125	67	20	10.40	0.113	162.2	155.4	76.2	87.3	99.2	53.8	3	1070
1080	2,050	3,600	80	27	17.90	0.172	193.0	180.8	88.9	104.8	118.4	64.5	3	1080
1090	3,730	3,600	95	27	25.60	0.254	212.0	199.8	98.4	123.8	127.4	71.6	3	1090
1100	6,280	2,440	110	42	42.00	0.426	250.7	246.2	120.6	142.1	156.6	-	5	1100
1110	9,320	2,250	120	42	54.30	0.508	270.0	259.0	127.0	160.3	162.6	-	5	1110
1120	13,700	2,025	140	61	81.20	0.735	306.4	304.4	149.2	179.4	191.7	-	6	1120
1130	19,900	1,800	170	67	121.00	0.907	343.8	329.8	161.9	217.5	195.5	-	6	1130
1140	28,600	1,650	200	67	178.00	1.130	383.8	374.4	184.2	254.0	201.7	-	6	1140

* Coupling Weight is without Bore Machining

T10 Type (Large)

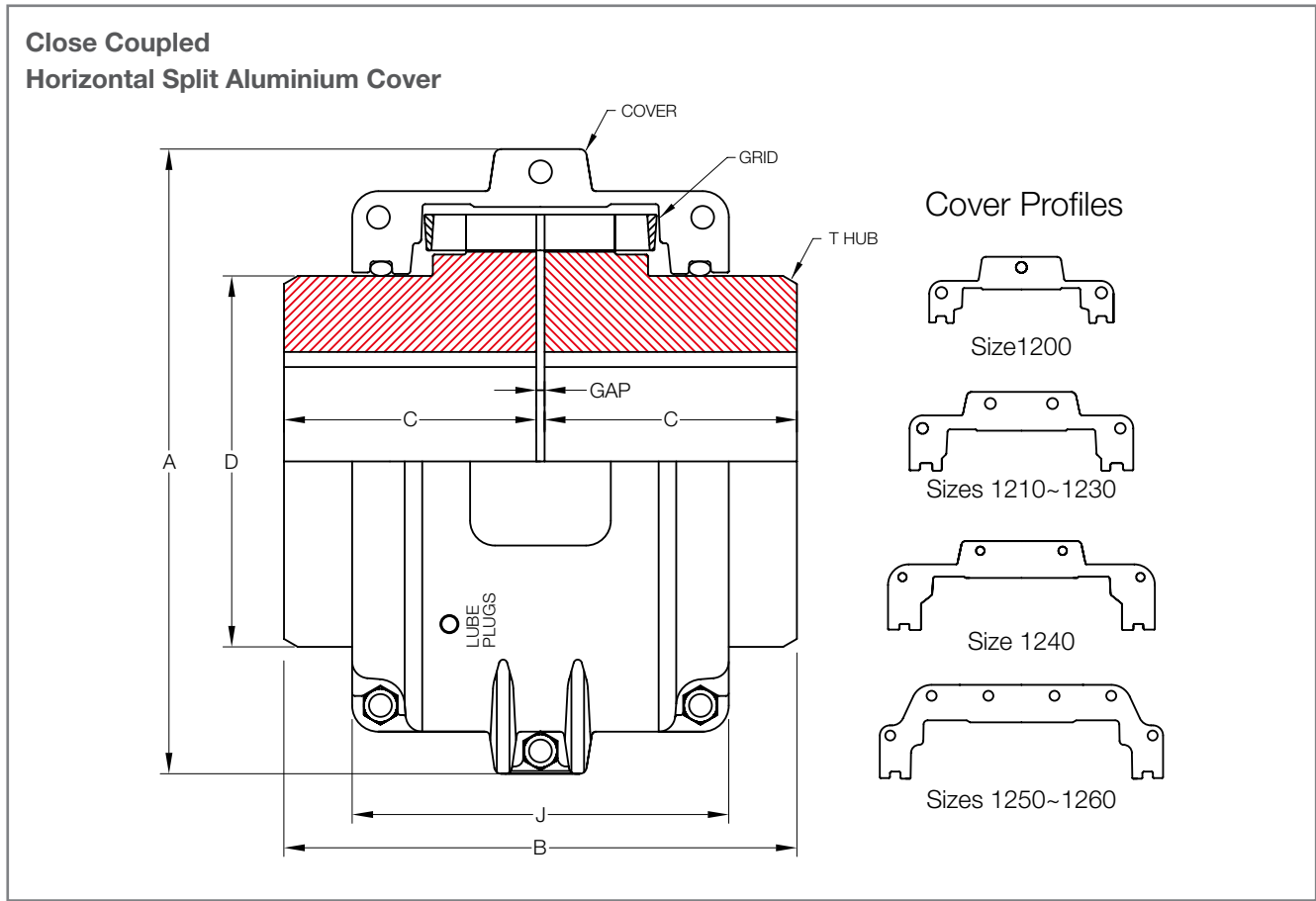

Size	Torque Rating (Nm)	Allow Speed RPM	Max Bore (mm)	Min Bore (mm)	Cplg Weight (Kg)	Lube Weight (Kg)	Dimensions (Millimeters)						Size
							A	B	C	D	J	GAP	
1150	39,800	1,500	215	108	234	1.95	453.1	371.8	182.9	269.2	271.5	6	1150
1160	55,900	1,350	240	121	317	2.81	501.9	402.2	198.1	304.8	278.4	6	1160
1170	74,600	1,225	280	134	448	3.49	566.9	437.8	215.9	355.6	307.3	6	1170
1180	103,000	1,100	300	153	619	3.76	629.9	483.6	238.8	393.7	321.1	6	1180
1190	137,000	1,050	335	153	776	4.40	675.6	524.2	259.1	436.9	325.1	6	1190
1200	186,000	900	360	178	1058	5.62	756.9	564.8	279.4	497.8	355.6	6	1200
1210	249,000	820	390	178	1424	10.50	844.6	622.6	304.8	533.4	431.8	13	1210
1220	336,000	730	420	203	1785	16.10	920.8	663.2	325.1	571.5	490.2	13	1220
1230	435,000	680	450	203	2267	24.00	1,003.3	703.8	345.4	609.6	546.1	13	1230
1240	559,000	630	480	254	2950	33.80	1,087.1	749.6	368.3	647.7	647.7	13	1240
1250	746,000	580	-	254	3833	50.10	1,181.1	815.6	401.3	711.2	698.5	13	1250
1260	932,000	540	-	254	4682	67.20	1,260.9	876.6	431.8	762.0	762.0	13	1260

* Coupling Weight is without Bore Machining

T20 Type

Close Coupled Vertical Split Steel Cover

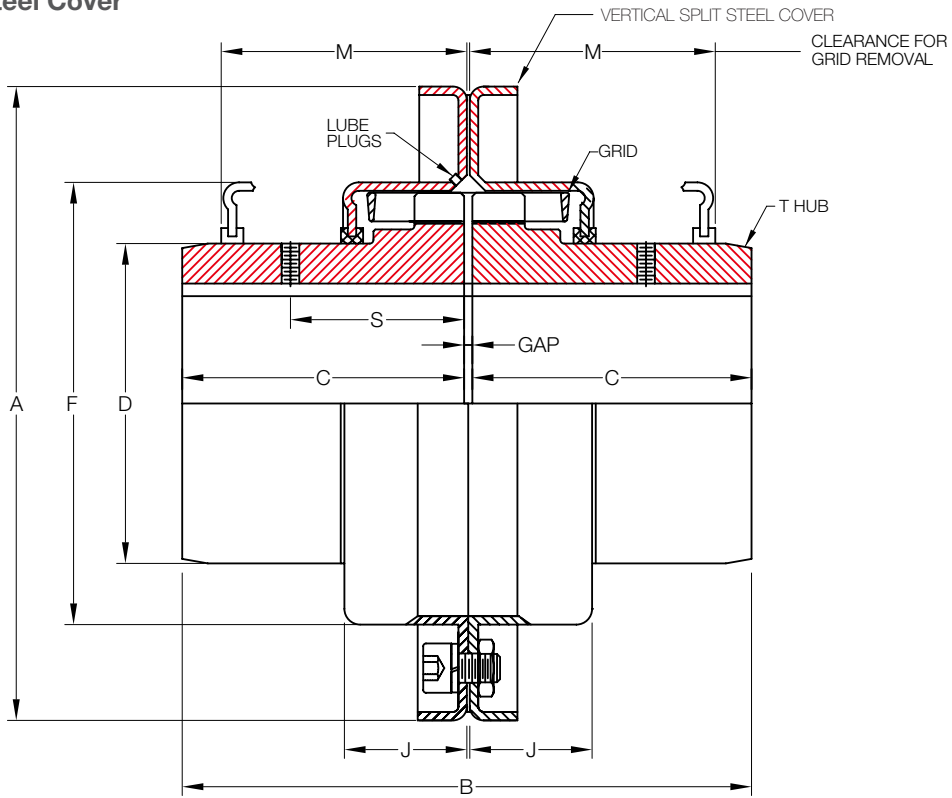

Size	Torque Rating (Nm)	Allow Speed RPM	Max Bore (mm)	Min Bore (mm)	Cplg Weight (Kg)	Lube Weight (Kg)	Dimensions (Millimeters)								Size
							A	B	C	D	F	J	M	GAP	
1020	52	6,000	28	13	1.94	0.0272	112.3	98.2	47.6	39.7	64.3	23.9	47.8	3	1020
1030	149	6,000	35	13	2.58	0.0408	121.8	98.2	47.6	49.2	73.8	24.9	47.8	3	1030
1040	249	6,000	43	13	3.35	0.0544	129.8	104.6	50.8	57.2	81.8	25.9	50.8	3	1040
1050	435	6,000	50	13	5.32	0.0680	148.8	123.6	60.3	66.7	97.6	30.5	60.5	3	1050
1060	684	6,000	56	20	7.01	0.0862	163.1	130.0	63.5	76.2	111.1	31.8	63.5	3	1060
1070	994	5,500	67	20	10.20	0.1130	174.2	155.4	76.2	87.3	122.3	33.5	66.5	3	1070
1080	2,050	4,750	80	27	17.60	0.1720	201.2	180.8	88.9	104.8	149.2	43.7	88.9	3	1080
1090	3,730	4,000	95	27	25.40	0.2540	232.9	199.8	98.4	123.8	168.3	47.0	95.2	3	1090
1100	6,280	3,600	110	42	42.00	0.4260	267.9	246.2	120.6	142.1	198.0	59.7	120.7	5	1100
1110	9,320	3,000	120	42	54.40	0.5080	286.9	259.0	127.0	160.3	216.3	62.7	124.0	5	1110
1120	13,700	2,700	140	61	81.80	0.7350	320.2	304.4	149.2	179.4	245.5	73.7	142.7	6	1120
1130	19,900	2,400	170	67	122.00	0.9070	379.0	329.8	161.9	217.5	283.8	74.9	146.0	6	1130
1140	28,600	2,200	200	67	180.00	1.1300	417.1	374.4	184.2	254.0	321.9	78.2	155.4	6	1140
1150	39,800	2,000	215	108	230.00	1.9500	476.2	371.8	182.9	269.2	374.4	107.3	203.2	6	1150
1160	55,900	1,750	240	121	321.00	2.8100	533.4	402.2	198.1	304.8	423.9	115.3	215.9	6	1160
1170	74,600	1,600	280	134	448.00	3.4900	584.2	437.8	215.9	355.6	474.7	120.1	226.1	6	1170
1180	103,000	1,400	300	153	591.00	3.7600	630.0	483.6	238.8	393.7	546.0	130.0	-	6	1180
1190	137,000	1,300	335	153	761.00	4.4000	685.0	524.2	259.1	436.9	589.0	135.0	-	6	1190
1200	186,000	1,100	360	178	1021.00	5.6200	737.0	564.8	279.4	497.8	652.0	145.0	-	6	1200

* Coupling Weight is without Bore Machining

T31 Type

Full Spacer Horizontal Split Aluminium Cover

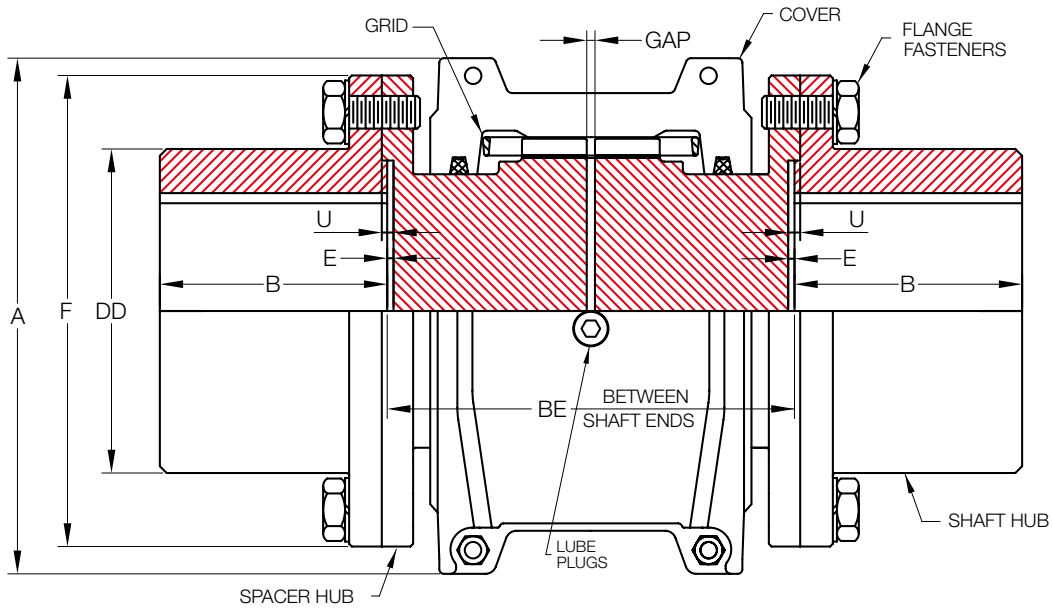

Size	Torque Rating (Nm)	Allow Speed RPM	Max Bore (mm)	Min Bore (mm)	Cplg Weight (Kg)	Add BE Weight (Kg)	Lube Weight (Kg)	Dimensions (Millimeters)									Flange Fasteners	
								A	B	BE		DD	E	F	U	GAP	No. per Flange	Dia (mm)
										Min	Max							
1020	52	4,500	35	13	3.85	0.010	0.0272	101.0	34.9	88.9	203	52.4	0.8	85.7	1.8	5	4	6.3
1030	149	4,500	43	13	5.21	0.016	0.0408	109.0	41.3	88.9	216	59.5	0.8	93.7	1.8	5	8	6.3
1040	249	4,500	56	13	8.43	0.021	0.0544	116.0	54.0	88.9	216	78.6	0.8	112.7	1.8	5	8	6.3
1050	435	4,500	67	13	12.80	0.028	0.0680	137.8	60.3	111.1	216	87.3	0.8	125.4	1.8	5	8	7.9
1060	684	4,350	80	20	20.50	0.037	0.0862	147.0	73.0	122.2	330	103.2	1.8	144.5	2.8	5	8	9.5
1070	994	4,125	85	20	24.80	0.048	0.1130	162.2	79.4	127.0	330	109.5	1.8	152.4	2.8	5	12	9.5
1080	2,050	3,600	95	27	40.00	0.069	0.1720	193.0	88.9	155.5	406	122.2	1.8	177.8	2.8	5	12	12.7
1090	3,730	3,600	110	27	60.10	0.100	0.2540	212.0	101.6	163.5	406	142.9	1.8	209.6	2.8	5	12	15.8
1100	6,280	2,440	130	39	90.20	0.120	0.4260	250.7	90.4	203.2	406	171.4	1.6	250.8	3.2	6	12	19.0
1110	9,320	2,250	150	51	119.00	0.160	0.5080	270.0	104.1	209.6	406	196.8	1.6	276.2	3.2	6	12	19.0
1120	13,700	2,025	170	64	178.00	0.200	0.7350	306.4	119.4	246.1	406	225.4	1.6	319.1	4.0	10	12	22.2
1130	19,900	1,800	190	77	237.00	0.290	0.9070	343.8	134.6	257.1	406	238.1	1.6	346.1	4.0	10	12	25.4
1140	28,600	1,650	210	89	327.00	0.400	1.1300	383.8	152.4	266.7	406	266.7	1.6	385.8	4.0	10	12	28.5
1150	39,800	1,500	270	102	462.00	0.190	1.9500	453.1	172.7	344.5	371.3	334.3	5.1	425.4	-	10	14	22.2
1160	55,900	1,350	290	115	566.00	0.250	2.8100	501.4	186.4	355.6	406.4	366.0	6.6	457.2	-	10	14	22.2
1170	74,600	1,225	340	127	856.00	0.380	3.4900	566.4	220.2	384.2	444.5	424.9	8.4	527.0	-	10	16	25.4
1180	103,000	1,100	340	102	1,135.00	0.470	3.7600	629.9	248.9	400.1	490.5	450.8	5.1	590.6	8.1	10	16	28.5
1190	137,000	1,050	380	115	1,525.00	0.600	4.4000	675.6	275.8	411.2	530.4	508.0	5.1	660.4	8.1	10	18	31.7
1200	186,000	900	400	127	1,910.00	0.850	5.6200	756.9	305.3	444.5	574.5	530.4	6.1	711.2	9.1	10	18	31.7

* Min BE Weight is Added Weight per Millimeters of BE over Minimum
 * Coupling Weight is with no Bore and Minimum BE

T35 Type

Half Spacer Horizontal Split Aluminium Cover

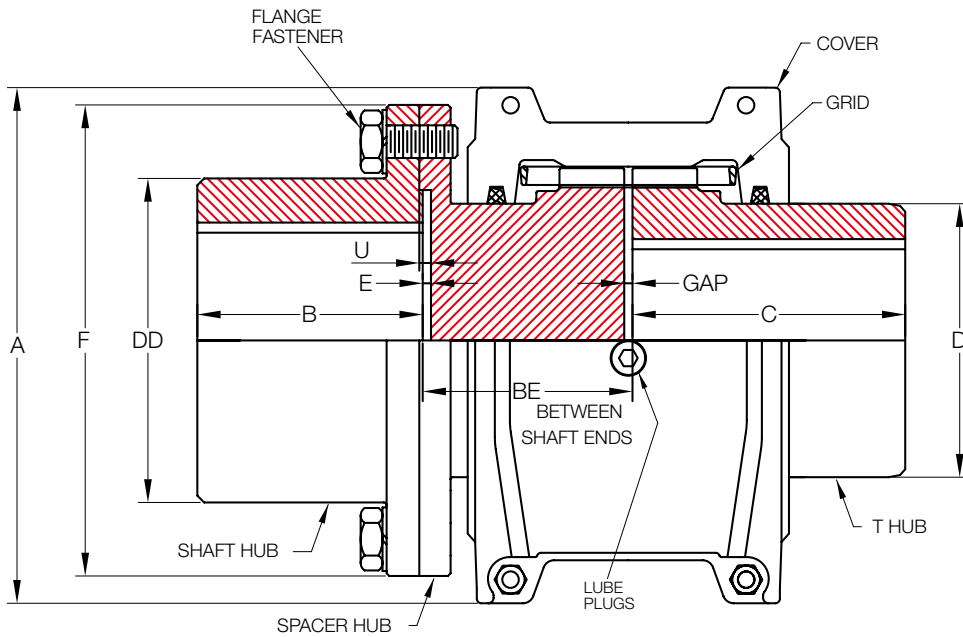

Size	Torque Rating (Nm)	Allow Speed RPM	Max Bore				Min Bore (mm)	Cplg Weight (Kg)	Add BE Weight (Kg)	Lube Weight (Kg)	Dimensions (Millimeters)										Flange Fasteners		
			Shaft Hub		T Hub						A	B	BE		C	D	DD	E	F	U	GAP	No. per Flange	Dia (mm)
			Max	Min	Max	Min							Min	Max									
1020	52	4,500	35	-	28	-	13	2.89	0.010	0.0272	97.0	34.9	45.2	102	47.6	39.7	52.4	0.8	85.7	1.8	3	4	6.3
1030	149	4,500	43	-	35	-	13	3.89	0.016	0.0408	105.7	41.3	45.2	109	47.6	49.2	59.5	0.8	93.7	1.8	3	8	6.3
1040	249	4,500	56	-	43	-	13	5.88	0.021	0.0544	114.3	54.0	45.2	109	50.8	57.2	78.6	0.8	112.7	1.8	3	8	6.3
1050	435	4,500	67	-	50	-	13	9.12	0.028	0.0680	135.1	60.3	56.3	109	60.3	66.7	87.3	0.8	125.4	1.8	3	8	7.9
1060	684	4,350	80	-	56	-	20	13.90	0.037	0.0862	147.8	73.0	61.9	166	63.5	76.2	103.2	1.8	144.5	2.8	3	8	9.5
1070	994	4,125	85	-	67	-	20	17.60	0.048	0.1130	158.8	79.4	64.3	166	76.2	87.3	109.5	1.8	152.4	2.8	3	12	9.5
1080	2,050	3,600	95	-	80	-	27	28.90	0.069	0.1720	190.5	88.9	78.6	204	88.9	104.8	122.2	1.8	177.8	2.8	3	12	12.7
1090	3,730	3,600	110	-	95	-	27	42.80	0.100	0.2540	211.1	101.6	82.6	204	98.4	123.8	142.9	1.8	209.6	2.8	3	12	15.8
1100	6,280	2,440	130	-	110	-	42	66.10	0.120	0.4260	251.0	90.4	103.2	205	120.6	142.1	171.4	1.6	250.8	3.2	5	12	19.0
1110	9,320	2,250	150	-	120	-	42	84.60	0.160	0.5080	269.7	104.1	106.4	205	127.0	160.3	196.8	1.6	276.2	3.2	5	12	19.0
1120	13,700	2,025	170	-	140	-	61	129.00	0.200	0.7350	307.8	119.4	124.6	205	149.2	179.4	225.4	1.6	319.1	4.0	6	12	22.2
1130	19,900	1,800	190	-	170	-	67	179.00	0.290	0.9070	345.9	134.6	130.1	205	161.9	217.5	238.1	1.6	346.1	4.0	6	12	25.4
1140	28,600	1,650	210	-	200	-	67	252.00	0.400	1.1300	384.0	152.4	134.9	205	184.2	254.0	266.7	1.6	385.8	4.0	6	12	28.5
1150	39,800	1,500	270	102	215	108	-	348.00	0.190	1.9500	453.1	172.7	174.5	187.5	182.9	269.2	334.3	5.1	425.4	-	6	14	22.2
1160	55,900	1,350	290	115	240	121	-	441.00	0.250	2.8100	501.4	186.4	179.6	204.7	198.1	304.8	366.0	6.6	457.2	-	6	14	22.2
1170	74,600	1,225	340	127	280	134	-	652.00	0.380	3.4900	566.4	220.2	194.1	223.8	215.9	355.6	424.9	8.4	527.0	-	6	16	25.4
1180	103,000	1,100	340	102	300	153	-	877.00	0.470	3.7600	629.9	248.9	201.7	246.9	238.8	393.7	450.8	5.1	590.6	8.1	6	16	28.5
1190	137,000	1,050	380	115	355	153	-	1,150.00	0.600	4.4000	675.6	275.8	207.3	266.7	259.1	436.9	508.0	5.1	660.4	8.1	6	18	31.7
1200	186,000	900	400	127	360	178	-	1,484.00	0.850	5.6200	756.9	305.3	223.8	289.1	279.4	497.8	530.4	6.1	711.2	9.1	6	18	31.7

* Min BE Weight is Added Weight per Millimeters of BE over Minimum
 * Coupling Weight is with no Bore and Minimum BE

T50 Type

Floating Shaft Steel Cover

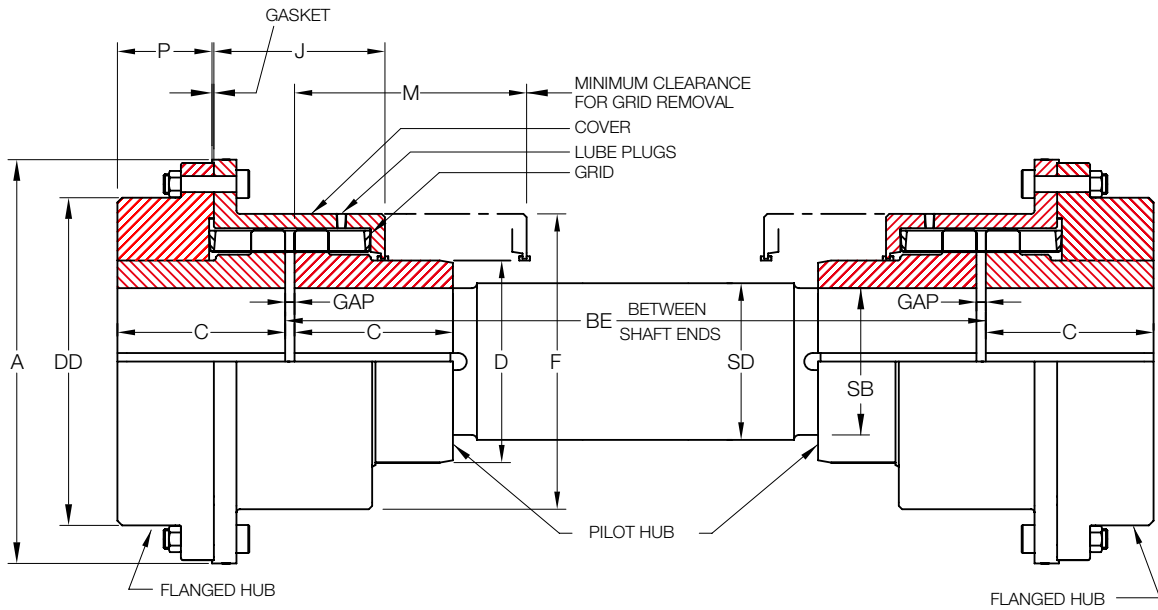

Size	Torque Rating (Nm)	Max Bore		Min Bore (mm)	Cplg Weight (Kg)	Lube Weight (Kg)	Dimensions (Millimeters)												
		Flanged Hub	Pilot Hub				A	BE Min	C	D	DD	F	J	M	P	SB	SD	GAP	
1030	149	35	27.0	13	3.90	0.0408	115.9	162	47.6	49.2	83.7	80.8	50.3	77.7	26.8	27.0	28.6	3	
1050	435	50	36.5	13	8.84	0.0680	157.5	195	60.3	66.7	105.2	104.8	59.2	94.0	36.2	36.5	38.1	3	
1070	994	67	49.2	20	15.60	0.1130	182.9	213	76.2	87.3	126.5	129.0	65.9	103.1	49.8	49.2	50.8	3	
1080	2,050	80	61.9	27	26.40	0.1720	218.4	275	88.9	104.8	154.9	156.2	85.9	134.1	52.1	61.9	63.5	3	
1090	3,730	95	74.6	27	37.20	0.2540	244.9	294	98.4	123.8	180.3	175.8	92.2	143.8	58.5	74.6	76.2	3	
1100	6,280	110	92.1	42	62.80	0.4260	286.0	372	120.6	142.1	211.3	208.3	117.3	181.4	69.3	92.1	95.2	5	
1110	9,320	120	101.6	42	83.60	0.5080	324.1	391	127.0	160.3	245.4	228.6	122.2	190.5	73.9	101.6	104.8	5	
1120	13,700	140	117.5	61	97.90	0.7350	327.2	453	149.2	179.4	179.3	257.0	146.3	220.0	83.6	117.5	120.6	6	
1130	19,900	170	133.4	67	140.00	0.9070	365.3	463	161.9	217.5	217.4	295.1	149.5	225.0	94.8	133.4	136.5	6	
1140	28,600	200	142.9	67	210.00	1.1300	419.1	482	184.2	254.0	254.0	335.8	155.8	234.7	113.8	142.9	146.0	6	
1150	39,800	215	161.9	108	277.00	1.9500	477.5	549	182.9	271.4	269.2	391.2	177.4	268.2	101.7	161.9	165.1	6	
1160	55,900	240	200.0	121	381.00	2.8100	548.6	587	198.1	304.8	304.8	442.0	189.4	287.0	111.9	200.0	203.2	6	
1170	74,600	280	200.0	134	519.00	3.4900	604.5	622	215.9	355.6	355.6	494.3	201.0	304.8	124.6	200.0	203.2	6	
1180	103,000	300	225.4	153	718.00	3.7600	665.5	673	238.8	393.7	393.7	556.3	226.9	330.2	141.4	225.4	228.6	6	
1190	137,000	335	250.8	153	898.00	4.4000	708.7	711	259.1	436.9	436.9	599.4	241.7	349.5	157.6	250.8	254.0	6	
1200	186,000	360	276.2	178	1,205.00	5.6200	782.3	744	279.4	497.8	497.8	622.9	251.8	365.8	172.8	276.2	279.4	6	

* Coupling Weight is without Bore Machining

T63 Type

Disc Brake

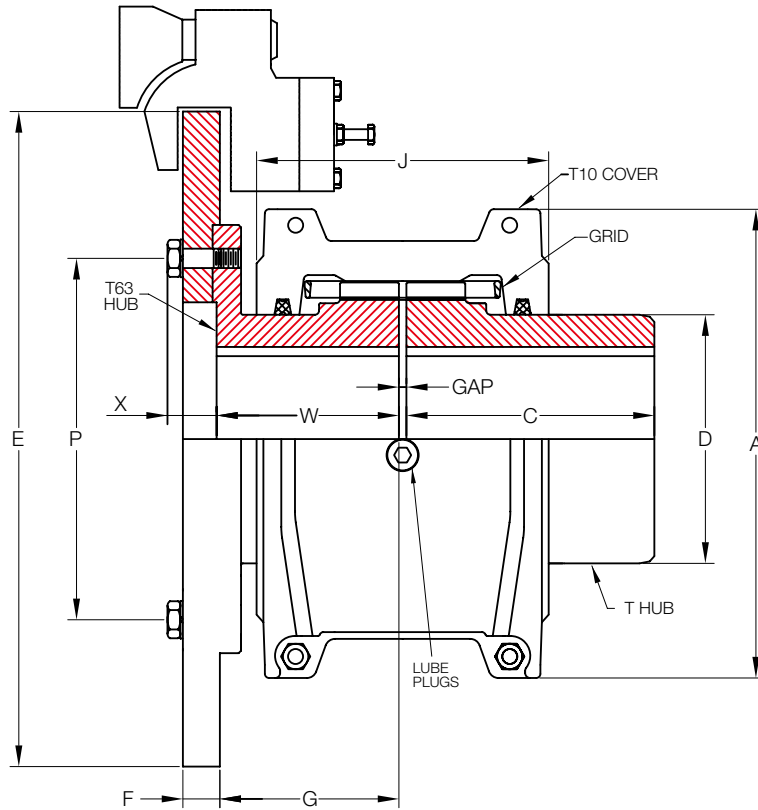

Size	Brake Rating (Nm)	Allow Speed RPM	Max Bore (mm)	Min Bore (mm)	Cplg Weight (Kg)	Lube Weight (Kg)	Dimensions (Millimeters)									Disc Brake Dia x Thickness (E x F)
							A	C	D	G	J	P	W	X	GAP	
1020	11	4,500	28	13	2.55	0.0272	97.0	47.6	39.7	59.9	67.8	71.4	60.5	11.7	3	203 x 6.4
1030	35	4,500	35	13	3.31	0.0408	105.7	47.6	49.2	59.9	71.9	79.4	60.5	11.7	3	254 x 6.4
1040	65	4,500	43	13	4.26	0.0544	114.3	50.8	57.2	59.9	72.0	98.4	60.5	11.7	3	254 x 6.4
1050	118	4,150	50	13	6.35	0.0680	135.1	60.3	66.7	59.9	81.6	108.0	60.5	13.2	3	254 x 6.4
1060	209	3,800	56	20	9.57	0.0862	147.8	63.5	76.2	88.6	97.9	125.4	88.1	15.2	3	305 x 6.4
1070	331	3,250	67	20	12.30	0.1130	158.8	76.2	87.3	88.6	99.2	133.4	88.1	15.2	3	305 x 6.4
1080	637	2,850	80	27	19.80	0.1720	190.5	88.9	104.8	88.6	118.4	152.4	88.1	18.0	3	305 x 6.4
1090	1,084	2,700	95	27	28.40	0.2540	211.1	98.4	123.8	87.9	127.4	179.4	88.1	26.9	3	407 x 12.7
1100	1,897	2,400	110	42	47.70	0.4260	251.0	120.6	142.1	119.1	156.6	215.9	119.1	29.5	5	407 x 12.7
1110	2,846	2,250	120	42	64.90	0.5080	269.7	127.0	160.3	146.0	162.6	241.3	146.0	29.5	5	458 x 12.7
1120	4,336	2,025	140	61	92.10	0.7350	307.8	149.2	179.4	150.1	191.7	276.2	149.4	33.0	6	509 x 12.7
1130	6,098	1,800	170	67	132.0	0.9070	345.9	161.9	217.5	153.4	195.5	295.3	152.4	35.6	6	509 x 12.7
1140	8,808	1,650	200	67	185.0	1.1300	384.0	184.2	254.0	159.8	201.7	330.2	158.8	38.1	6	610 x 12.7
1150	12,195	1,500	215	108	253.0	1.9500	453.1	182.9	269.2	179.8	271.5	368.3	182.9	31.5	6	763 x 12.7
1160	16,938	1,350	240	121	336.0	2.8100	501.9	198.1	304.8	195.1	278.4	400.0	198.1	31.5	6	915 x 12.7

* Coupling Weight is without Disc and Bore Machining

KBW Type

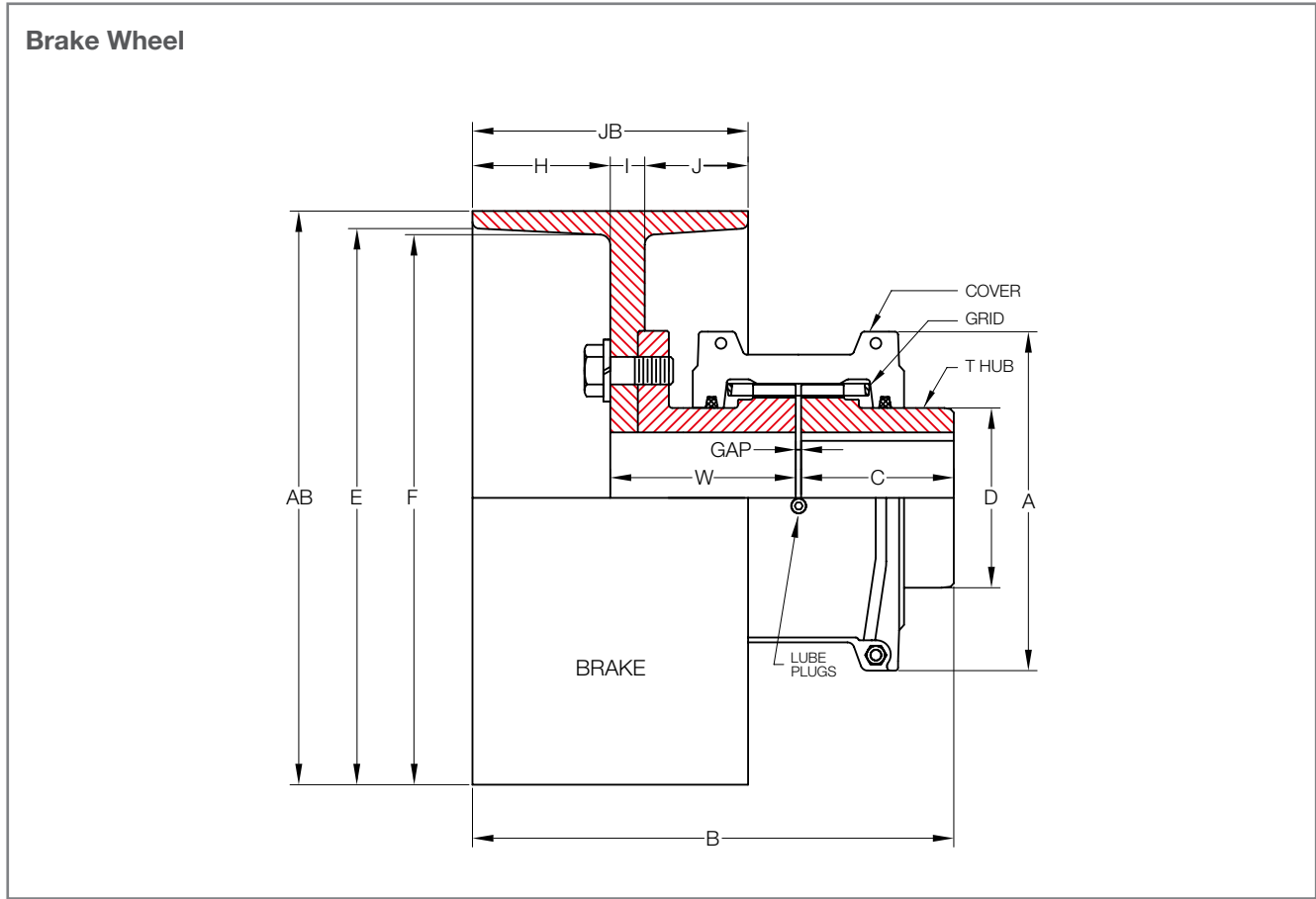

Size	Brake Rating (mm)	Max Bore (mm)	Min Bore (mm)	Lube Weight (Kg)	Dimensions (Millimeters)									Brake Wheel Size	
					A	C	D	E	F	H	I	J	GAP	AB (mm)	JB (mm)
1020	10.78	30	12.7	0.03	101.0	47.6	39.7	-	-	-	-	-	3	-	-
1030	35.18	36	12.7	0.03	109.0	47.6	49.2	-	-	-	-	-	3	-	-
1040	64.97	44	12.7	0.05	116.0	50.8	57.2	145.0	140.0	40.0	12.0	28.0	3	160	80
1050	117.80	50	12.7	0.05	137.8	60.3	66.7	184.0	178.0	50.0	17.0	33.0	3	200	100
1060	208.64	57	19.1	0.09	147.0	63.5	76.2	184.0	178.0	50.0	17.0	33.0	3	200	100
1070	330.55	68	19.1	0.11	162.2	76.2	87.3	230.0	224.0	62.5	22.0	40.5	3	250	125
1080	636.71	82	27.0	0.17	193.0	88.9	104.8	292.0	285.0	80.0	23.0	57.0	3	315	160
1090	1,083.88	95	27.0	0.25	212.0	98.4	123.8	330.0	320.0	90.0	26.0	64.0	3	355	180
1100	1,896.79	107	41.3	0.43	250.7	120.6	142.1	374.0	362.0	100.0	28.0	72.0	5	400	200
1110	2,845.14	117	41.3	0.51	270.0	127.0	160.3	422.0	410.0	112.0	32.0	80.0	5	450	224
1120	4,335.52	136	60.3	0.73	306.4	149.2	179.4	462.0	445.0	125.0	35.0	90.0	6	500	250
1130	6,488.78	165	66.7	0.91	343.8	161.9	217.5	516.0	495.0	140.0	45.0	95.0	6	560	280
1140	8,806.48	184	66.7	1.13	383.8	184.2	254.0	516.0	495.0	140.0	45.0	95.0	6	560	280

* Coupling Weight is without Bore Machining

T10 / G82 Type

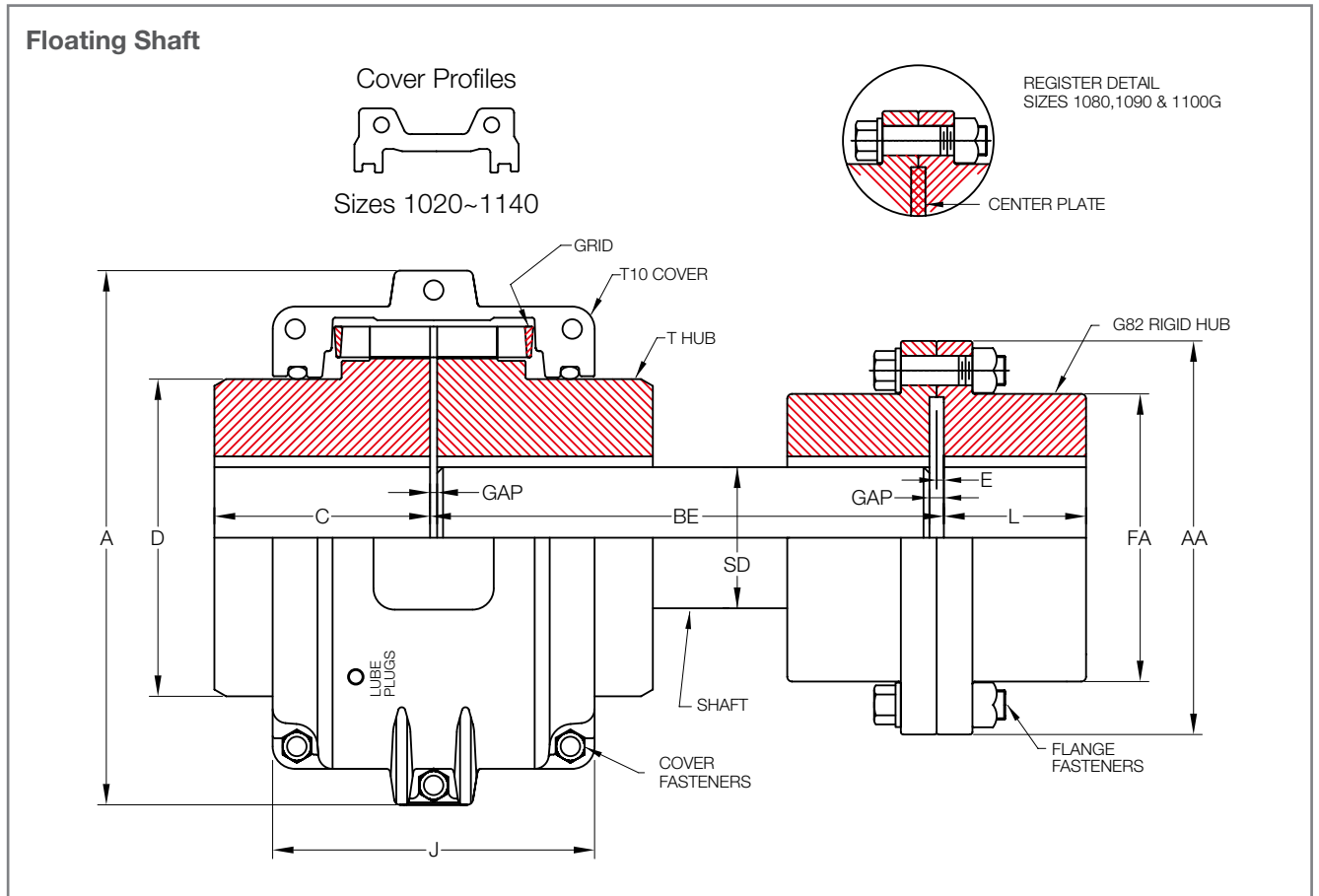

T10 Cplg Size	G82 Cplg Size	Torque Rating (Nm)	Allow Sped RPM	Max Bore		Min Bore		Cplg Weight (Kg)	Add BE Weight (Kg)	Lube Weight (Kg)	Fasteners	
				T10 Hub (mm)	G82 Hub (mm)	T10 Hub (mm)	G82 Hub (mm)				No. per Flange	Dia (mm)
1110	1035	9,320	2,250	120	164	42	51	125	0.0804	0.508	8	0.750
1120	1040	13,700	2,025	140	196	61	64	183	0.0992	0.735	8	0.750
1130	1045	19,900	1,800	170	216	67	76	261	0.1430	0.907	10	0.750
1140	1050	28,600	1,650	200	242	67	89	382	0.2090	1.130	8	0.875
1150	1055	39,800	1,500	215	267	108	102	508	0.2540	1.950	14	0.875
1160	1060	55,900	1,350	240	293	121	115	645	0.3220	2.810	14	0.875
1170	1070	74,600	1,225	280	341	134	127	983	0.3970	3.490	16	1.000
1180	1080	103,000	1,100	300	341	153	102	1313	0.4800	3.760	16	1.125
1190	1090	137,000	1,050	335	380	153	115	1756	0.5720	4.400	18	1.250
1200	1100	186,000	900	360	405	178	127	2254	0.6710	5.620	18	1.250

T10 Cplg Size	G82 Cplg Size	Dimensions (Millimeters)											GAP	
		A	BE		C	D	E	J	L	AA	FA	SD	T Hub	G82 Hub
			Min	Max										
1110	1035	269.7	239.0	304.8	127.0	160.3	2.5	161.5	102.1	279.4	211.3	114.3	5	5
1120	1040	307.8	279.1	355.6	149.2	179.4	4.1	191.5	115.3	317.5	245.4	127.0	6	8
1130	1045	345.9	307.1	381.0	161.9	217.5	4.1	195.1	130.6	345.9	274.1	152.4	6	8
1140	1050	384.0	348.0	406.4	184.2	254.0	5.1	201.2	147.3	388.9	305.8	184.2	6	10
1150	1055	453.1	372.1	406.4	182.9	269.2	5.1	271.5	172.7	425.4	334.3	203.2	6	10
1160	1060	501.9	404.1	457.2	198.1	304.8	6.6	278.4	186.4	457.2	366.0	228.6	6	13
1170	1070	566.9	459.2	508.0	215.9	355.6	8.4	307.3	220.2	527.0	424.9	254.0	6	17
1180	1080	629.9	510.3	660.4	238.8	393.7	8.1	321.1	248.9	590.6	450.8	279.4	6	16
1190	1090	675.6	557.5	711.2	259.1	436.9	8.1	325.1	275.8	660.4	508.0	304.8	6	16
1200	1100	756.9	609.3	762.0	279.4	497.8	9.1	355.6	305.3	711.2	530.4	330.2	6	18

* Coupling Weight is with no Bore and Shaft
 * Shaft Weight is Added Weight per Millimeter of SD dia Between Hubs

Taper Grid Couplings

Installation

Requirements are wrenches, a straight edge and feeler gauges to install KCP Taper Grid Couplings. Taper Grid Coupling size from 1020 to 1090 are furnished for a clearance fit with a setscrew over the keyway. Larger sizes (from 1100 and up) are furnished for an interference fit without a setscrew.

Clearance fit Hubs : Clean all parts using a non-flammable solvent. Check hubs, shafts and key ways for burrs. Install keys. Mount hubs with the flange face flush with shaft ends (or as otherwise specified). Tighten setscrews. Do not heat clearance fit hubs.

Interference Fit Hubs : Furnished without setscrews.

1) Mount Seals and Hubs

Lock out starting switch of prime mover. Clean metal parts using a non-flammable solvent. Lightly coat seals with grease and place on shafts before mounting hubs. Heat interference fit hubs. Seal keyways to prevent leakage. Mount hubs on their corresponding shafts so that the hub face is flush with the end of the shaft (unless otherwise indicated).

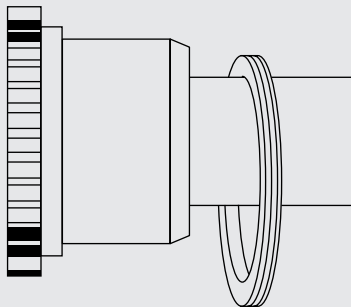

2) Gap and Alignment

Use a spacer bar equal in thickness to the gap between shafts (Page 11-12) Insert bar and same depth at 90° intervals and measure clearance between bar and hub face with feelers. The difference in minimum and maximum measurements must not exceed the angular installation limits.

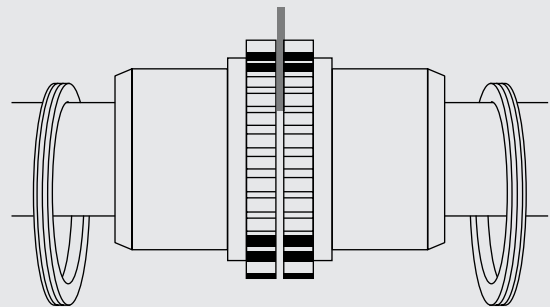

3) Offset Alignment

Align a straight edge so that it rests squarely on both hubs as shown in the diagram. Check with feelers. The clearance must not exceed the parallel offset installation limits. Tighten all foundation bolts and repeat Steps 2 and 3. Realign coupling if necessary.

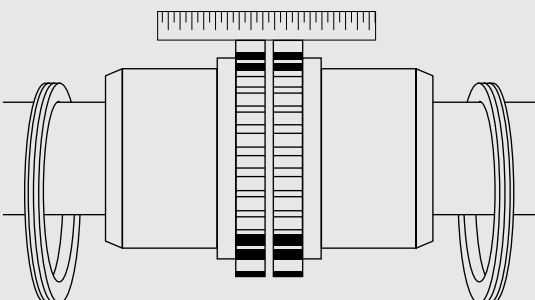

4) Insert Grid

Pack the gap and grooves with specified lubricant before inserting grid. When grids are furnished in two or more segments, install them so that all cut ends extend in the same direction. This will assure correct contact between the grid and any non-rotating pins in each half of the covers. Spread the grid just enough so that it passes over the coupling teeth. Seat with a soft mallet.

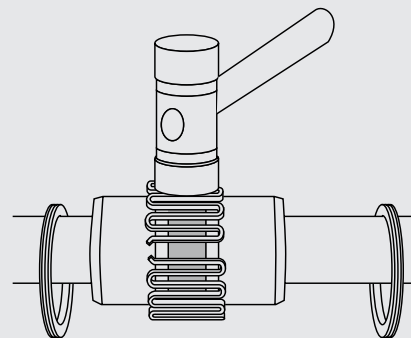

Installation

5) Pack

Pack any spaces between and around the grid with as much lubricant as possible. Wipe off any excess so that any remaining lubricant is flush with top of grid. Position hub seals to line up with the grooves in the cover. Position gaskets on lower cover half flange and assemble the two covers so that the match marks are on the same side. If shafts are not horizontally level, or if the coupling is to be used vertically, assemble cover halves with the lug so that the match marks are up or are on the high side. Push gaskets in against the seals as far as possible. Secure cover halves with fasteners and tighten to torque. Make sure gaskets stay in position while the fasteners are tightened.

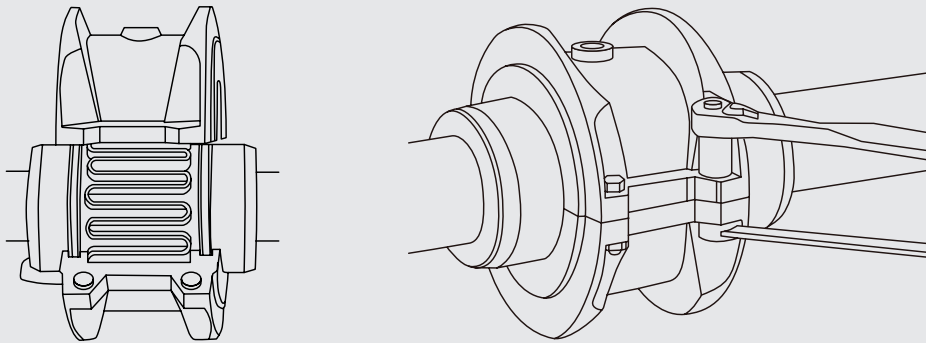

Annual Maintenance

Items to perform annually :

1. Check alignment. If the maximum operating misalignment limits are exceeded, realign the coupling to the recommended installation limits.
2. Check that all fasteners are tightened to torque.
3. Inspect Oil Seal and Gasket to determine if replacement is required. Replace if the Seal and Gasket is leaking grease.
4. Disassemble the coupling and inspect for wear. Replace any worn parts. Clean grease from coupling and repack with new grease. Install coupling using a new gasket as instructed in this manual.

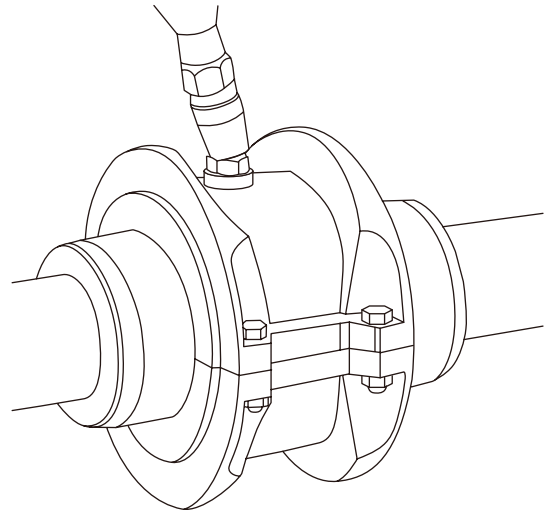

Taper Grid Couplings

Alignment Data

Accurate alignment results in the maximum life and minimum maintenance for the coupling and the connected machinery. The amount of time for a coupling to reach its maximum operating limits is a function of load, operating speed, and lubrication. Maximum operating values listed in the table below are based on the allowable RPM listed on the catalogue. Values listed are based on the use of the specified gaps, use of standard coupling components, standard assemblies, and catalogue allowable speeds. Values may be combined for an installation or operating condition. Parallel misalignment is the distance between the centers of each shaft. Angular misalignment is dimension X minus dimension Y as shown in the drawing below. End float is the axial movement of the hubs within the covers as measured from "0" gap. This measure assumes zero angular and zero parallel misalignment.

Parallel Misalignment

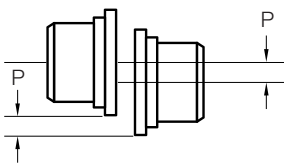

Angular Misalignment

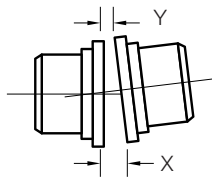

End Float

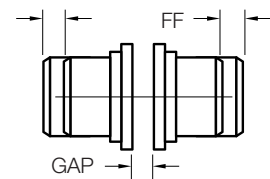

Misalignment Capacity

Size	Recommended Installation		Operating		Fastener Tightening Torque Values (Nm)
	Parallel Offset-P Max (mm)	Angular (X-Y) Max (mm)	Parallel Offset-P Max (mm)	Angular (X - Y) Max (mm)	
1020	0.15	0.08	0.30	0.25	11.30
1030	0.15	0.08	0.30	0.30	11.30
1040	0.15	0.08	0.30	0.33	11.30
1050	0.20	0.10	0.41	0.41	22.60
1060	0.20	0.13	0.41	0.46	22.60
1070	0.20	0.13	0.41	0.51	22.60
1080	0.20	0.15	0.41	0.61	22.60
1090	0.20	0.18	0.41	0.71	22.60
1100	0.25	0.20	0.51	0.84	35.00
1110	0.25	0.23	0.51	0.91	35.00
1120	0.28	0.25	0.56	1.02	73.00
1130	0.28	0.30	0.56	1.19	73.00
1140	0.28	0.33	0.56	1.35	73.00
1150	0.28	0.41	0.60	1.57	-
1160	0.30	0.46	0.60	1.78	-
1170	0.30	0.51	0.60	2.01	-
1180	0.38	0.56	0.76	2.26	-
1190	0.38	0.61	0.76	2.46	-
1200	0.38	0.69	0.76	2.72	-
1210	0.46	0.74	0.91	3.00	-
1220	0.46	0.81	0.91	3.28	-
1230	0.46	0.89	0.97	3.61	-
1240	0.48	0.97	0.97	3.91	-
1250	0.51	1.07	1.02	4.29	-

Puller Holes

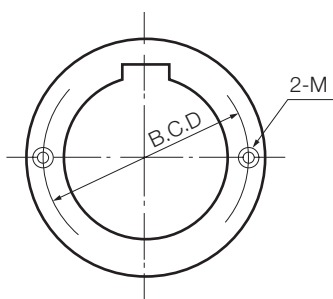

Size	B.C.D (mm)	Tap Size
1150	263	M16 x 2.0 x 24
1160	298	M22 x 2.5 x 27
1170	338	M30 x 3.5 x 32
1180	378	M30 x 3.5 x 38
1190	413	M36 x 4.0 x 45
1200	456	M36 x 4.0 x 45

Size	B.C.D (mm)	Tap Size
1210	497	M36 x 4.0 x 45
1220	541	M36 x 4.0 x 45
1230	586	M36 x 4.0 x 45
1240	633	M36 x 4.0 x 45
1250	690	M36 x 4.0 x 45
1260	749	M36 x 4.0 x 45

Gear Couplings

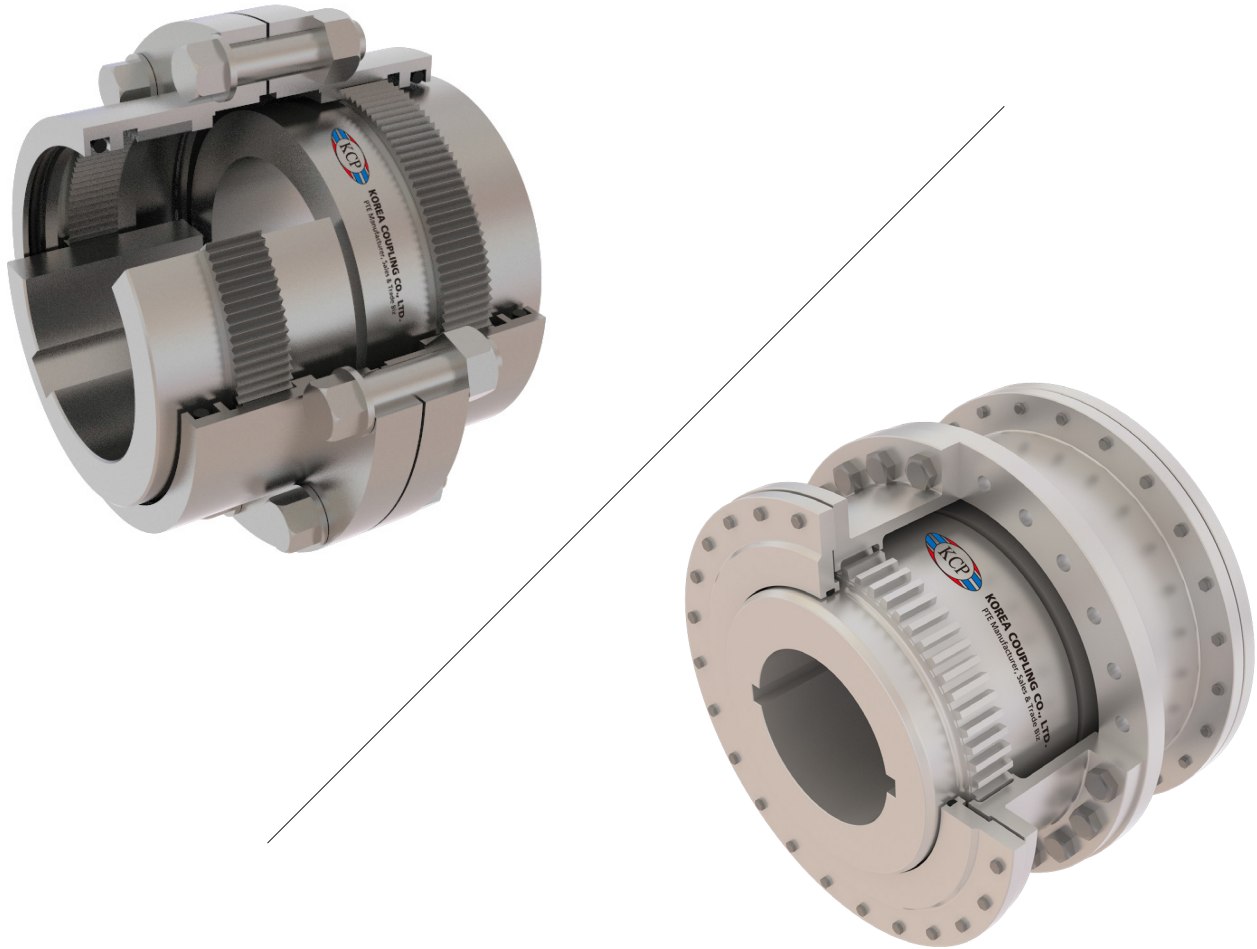

KCP Gear Couplings serve as a mechanical device which connect the shafts of two distinct machines and can accommodate large axial moments as well as small amounts of shaft misalignment.

Commercial Gear Couplings transmit more torque than other types of couplings of similar physical size. Because of this superior load transmitting capability, Gear Couplings have become widely used for higher speed applications, as well as for applications that require a combination of high torque capacity and a low inertia of the drive system.

Gear Couplings are torsionally rigid and couple two designs, one of which is completely flexible and one of which is rigid. Gear Couplings consist of two shaft hubs with external teeth, which are then connected by means of a sleeve, usually two pieces, containing internal teeth. A flexible spline with the hubs and sleeves rotating together is the working action of a Gear Coupling. The proper type of lubrication, applied frequently and adequately, is essential for the successful operation of this system.

This coupling is made up of one flexible geared half and on rigid half. A flexible & rigid coupling such as this is primarily used for "floating shaft" applications. The coupling accommodates angular misalignment but does not accommodate parallel displacement of shafts.

Gear Coupling Types



G20 Type

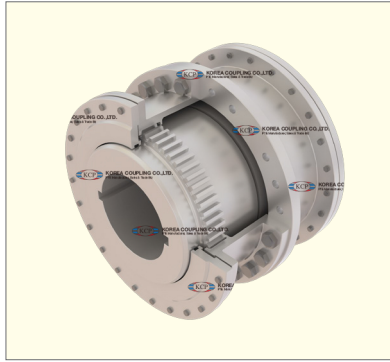

G20 Type (Large)

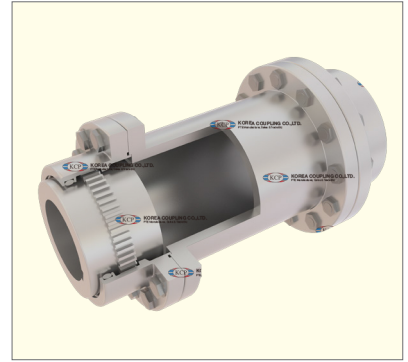

G32 Type

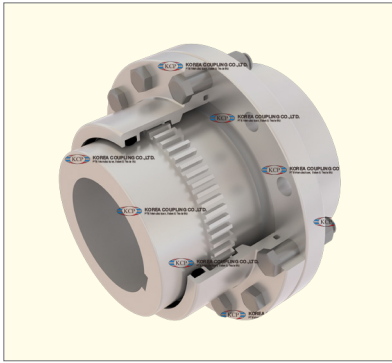

G52 Type

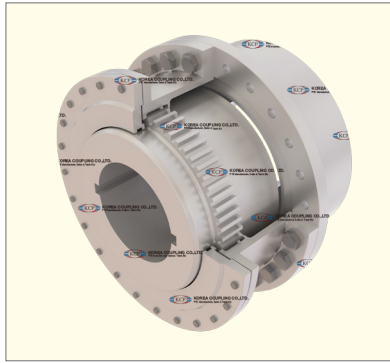

G52 Type (Large)



G52 Type (Floating Shaft)

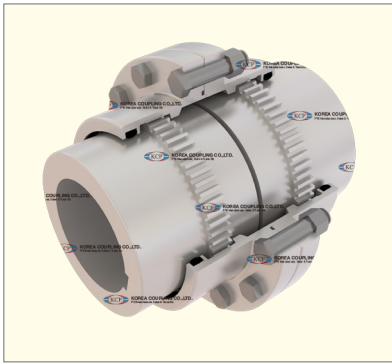

KSS Type



KCC Type

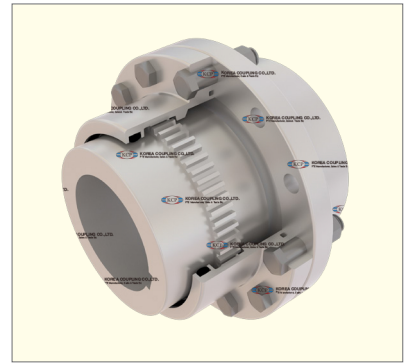

KSE Type



KCE Type



KSP Type

G20 Type

Standard Flanged Sleeve Double Engagement

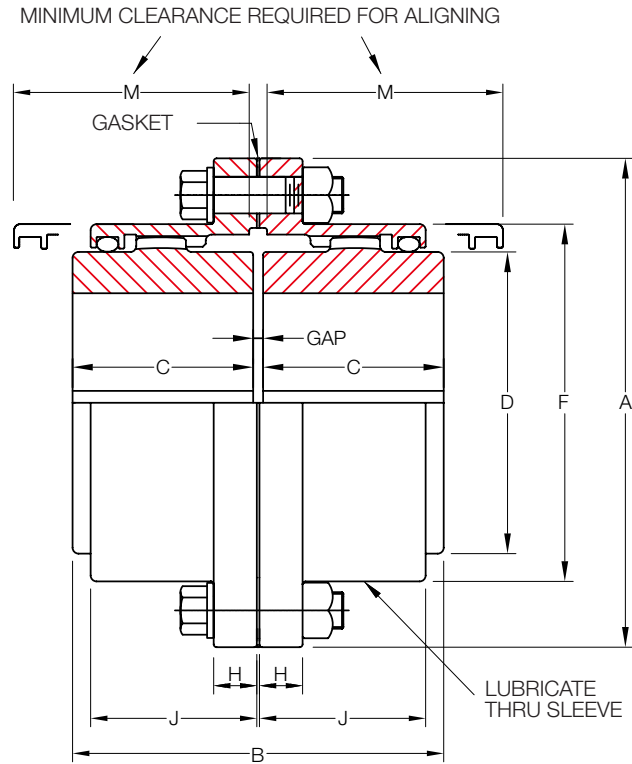

Size	Torque Rating (Nm)	Allow Speed RPM	Max Bore (mm)	Min Bore (mm)	Cplg Weight G20 (Kg)	Lube Weight (Kg)	Dimensions (Millimeters)								
							A	B	C	D	F	H	J	M	GAP
1010	1,140	8,000	50	13	4.54	0.0408	115.9	88.9	42.9	68.6	83.8	14.0	38.9	51	3
1015	2,350	6,500	65	20	9.07	0.0726	152.4	101.6	49.3	86.4	105.2	19.0	47.8	61	3
1020	4,270	5,600	78	26	15.90	0.1130	177.8	127.0	62.0	105.2	126.5	19.0	59.4	77	3
1025	7,470	5,000	98	32	29.50	0.2127	212.7	158.9	77.0	130.6	154.9	21.8	71.6	92	5
1030	12,100	4,400	111	39	43.10	0.3630	239.7	187.4	91.2	152.4	180.3	21.8	83.8	107	5
1035	18,500	3,900	134	51	68.00	0.5440	279.4	218.9	106.4	177.8	211.3	28.4	97.5	130	6
1040	30,600	3,600	160	64	97.50	0.9070	317.5	247.3	120.6	209.6	245.4	28.4	111.3	145	6
1045	42,000	3,200	183	77	136.00	1.0400	346.1	277.7	134.9	235.0	274.1	28.4	122.9	166	8
1050	56,600	2,900	200	89	191.00	1.7700	388.9	314.3	153.2	254.0	305.8	38.1	140.7	183	8
1055	74,000	2,650	220	102	249.00	2.2200	425.4	344.3	168.1	279.4	334.3	38.1	158.0	204	8
1060	90,400	2,450	244	115	306.00	3.1800	457.2	384.4	188.2	304.8	366.0	25.4	169.2	229	8
1070	135,000	2,150	289	127	485.00	4.3500	527.0	451.5	220.7	355.6	424.9	28.4	195.6	267	10

* Coupling Weight is without Bore Machining

G20 Type (Large)

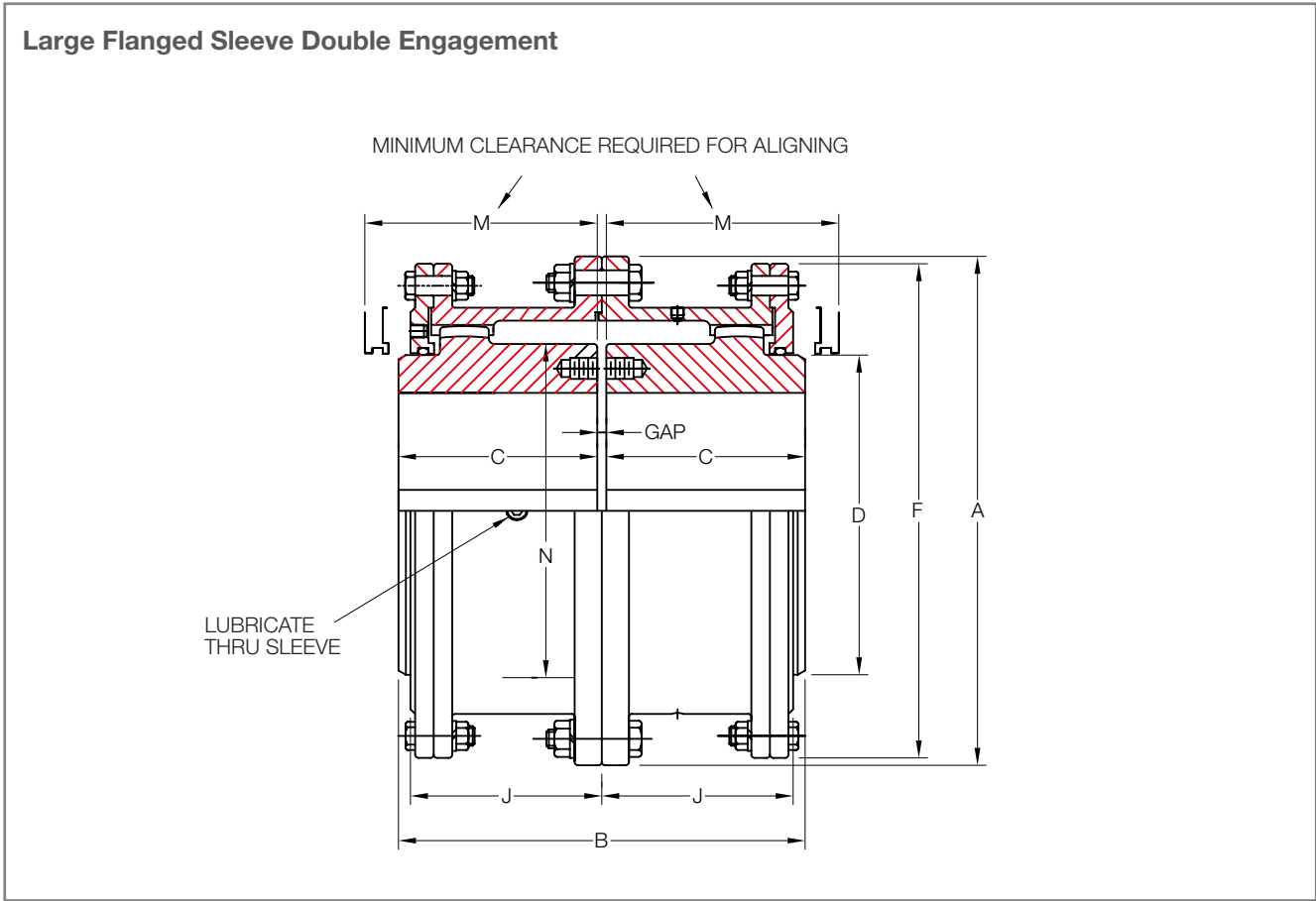

Size	Torque Rating (Nm)	Allow Speed RPM	Max Bore (mm)	Min Bore (mm)	Cplg Weight (Kg)	Lube Weight (Kg)	Dimensions (Millimeters)								
							A	B	C	D	F	J	M	N	GAP
1080	170,000	1,750	266	101.60	703	9.5	590.6	508.5	249.2	355.6	571.5	242.8	300.0	368.3	10
1090	226,000	1,550	290	114.30	984	12.2	660.4	565.4	276.4	393.7	641.4	265.2	327.2	419.1	13
1100	310,000	1,450	320	127.00	1,302	15.0	711.2	622.3	304.8	444.5	698.5	293.6	355.6	469.9	13
1110	413,000	1,330	373	139.70	1,678	17.7	774.7	679.2	333.2	495.3	479.3	322.3	384.0	520.7	13
1120	555,000	1,200	400	152.40	2,114	20.9	838.2	717.8	352.6	546.1	825.5	341.4	403.4	571.5	13
1130	719,000	1,075	440	165.10	2,595	32.7	911.4	761.7	371.3	584.2	886	362.0	434.8	609.6	19
1140	911,000	920	460.0	177.80	3,107	33.1	965.2	806.4	393.2	635.0	939.8	378.0	457.2	660.4	19
1150	1,100,000	770	490.0	190.50	3,765	40.8	1,028.7	857.2	419.1	685.8	1,003.3	407.9	482.6	711.2	19
1160	1,310,000	650	525	254.00	4,708	43.1	1,111.2	908.0	441.3	736.6	1,085.9	419.1	504.6	762	25
1180	1,660,000	480	600	285.75	6,260	49.9	1,219.2	939.8	457.2	838.2	1,193.8	434.8	520.7	863.6	25
1200	2,140,000	370	660	317.50	8,582	68.0	1,358.9	1,098.60	536.6	927.1	1,308.1	514.4	635.0	965.2	25
1220	2,720,000	290	725	349.25	11,685	107.0	1,511.3	1,193.80	584.2	1,016.0	1,473.2	565.2	685.8	1,066.8	25

* Coupling Weight is without Bore Machining

G32 Type

Standard Flanged Sleeve Spacer

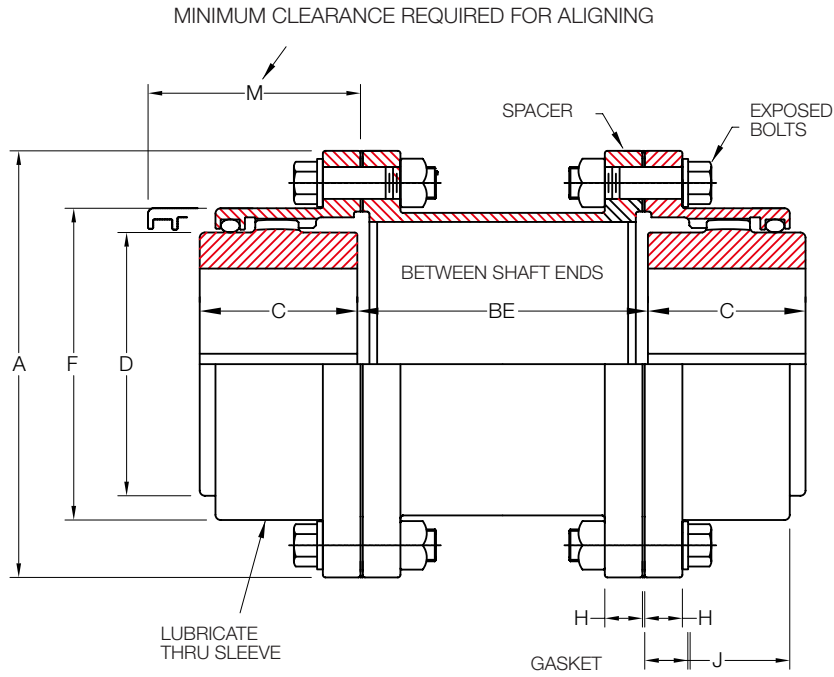

Size	Torque Rating (Nm)	Allow Speed RPM	Max Bore (mm)	Min Bore (mm)	Cplg Weight (Kg)		Lube Weight (Kg)		Dimensions (Millimeters)								
					Cplg (Kg)	Spacer (Kg)	Less Spacer (Kg)	Add Spacer mm (Kg)	A	BE Min		C	D	F	H	J	M
										G31	G32						
1010	1,140	7,000	50	13	6.8	0.0120	0.0408	-	115.9	82	82	42.9	68.6	83.8	14.0	38.9	48
1015	2,350	5,500	65	20	13.6	0.0127	0.0726	-	152.4	82	82	49.3	86.4	105.2	19.0	47.8	56
1020	4,270	4,600	78	26	20.4	0.0166	0.1130	0.00054	177.8	82	82	62.0	105.2	126.5	19.0	59.4	69
1025	7,470	4,000	98	32	38.6	0.0205	0.2270	0.00107	212.7	108	95	77.0	130.6	154.9	21.8	71.6	81
1030	12,100	3,600	111	39	54.4	0.0236	0.3630	0.00107	239.7	108	95	91.2	152.4	180.3	21.8	83.8	94
1035	18,500	3,100	134	51	88.5	0.0359	0.5440	0.00214	279.4	130	120	106.4	177.8	211.3	28.4	97.5	107
1040	30,600	2,800	160	64	122.5	0.0500	0.9070	0.00357	317.5	130	120	120.6	209.6	245.4	28.4	111.3	122
1045	42,000	2,600	183	77	166.0	0.0736	1.0400	0.00357	346.1	130	120	134.9	235.0	274.1	28.4	122.9	135
1050	56,600	2,400	200	89	238.0	0.0814	1.7700	0.00357	388.9	184	146	153.2	254.0	305.8	38.1	140.7	152
1055	74,000	2,200	220	102	306.0	0.0895	2.2200	0.00357	425.4	184	146	168.1	279.4	334.3	38.1	158.0	173
1060	90,400	2,100	244	115	358.0	0.1170	3.1800	0.00357	457.2	-	146	188.2	304.8	366.0	25.4	169.2	183
1070	135,000	1,800	289	127	562.0	0.1410	4.3500	0.00357	527.0	-	146	220.7	355.6	424.9	25.4	195.6	208

* Plus Spacer Weight is Plus per Millimeters of Spacer Length
 * Coupling Weight is without Bore Machining
 * Spacer Weight is Extra Spaeer Weight per Millimeters of Length
 * Less Spacer Weight is Minimum Weight Less Spacer

G52 Type

Standard Flanged Sleeve Single Engagement

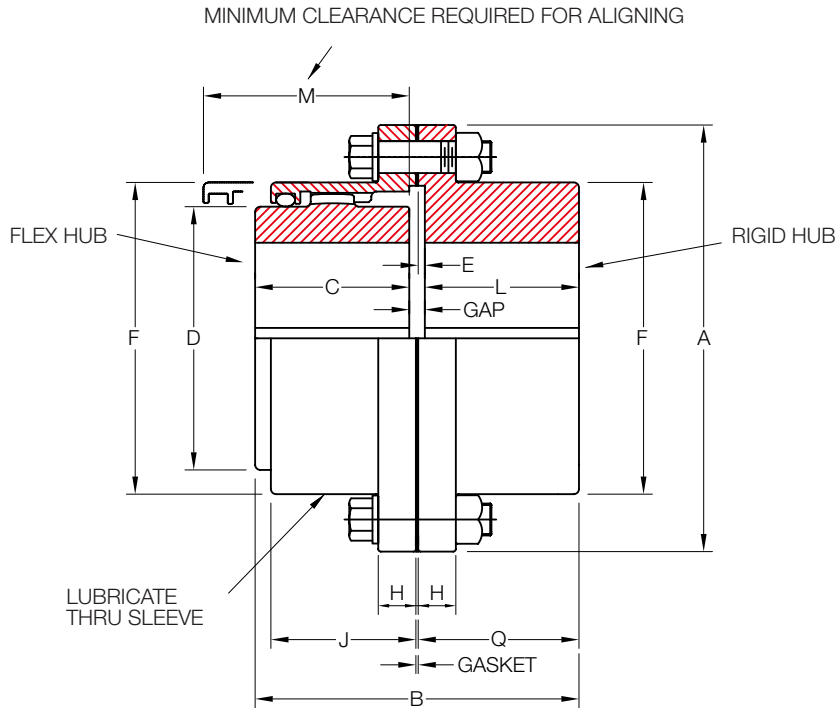

Size	Torque Rating (Nm)	Allow Speed RPM	Max Bore		Min Bore (mm)	Cplg Weight (Kg)	Lube Weight (Kgt)	Dimensions (Millimeters)											
			Flex (mm)	Rigid (mm)				A	B	C	D	E	F	H	J	L	M	Q	GAP
1010	1,140	8,000	50	65	13	4.08	0.023	115.9	86.6	42.9	68.6	2.5	83.8	14.0	38.9	39.6	51	42.2	4
1015	2,350	6,500	65	80	20	8.16	0.041	152.4	99.6	49.3	86.4	2.5	105.2	19.0	47.8	46.2	61	48.8	4
1020	4,270	5,600	78	98	26	13.6	0.068	177.8	124.5	62.0	105.2	2.5	126.5	19.0	59.4	58.4	76	61.0	4
1025	7,470	5,000	98	118	32	24.9	0.118	212.7	155.4	77.0	130.6	2.5	154.9	21.8	71.6	73.7	91	76.2	5
1030	12,100	4,400	111	140	39	38.6	0.181	239.7	183.9	91.2	152.4	2.5	180.3	21.8	83.8	87.9	107	90.4	5
1035	18,500	3,900	134	163	51	61.2	0.272	279.4	214.1	106.4	177.8	2.5	211.3	28.4	97.5	102.1	130	104.6	6
1040	30,600	3,600	160	196	64	90.7	0.467	317.5	242.8	120.6	209.6	4.1	245.4	28.4	111.3	115.3	145	119.4	7
1045	42,000	3,200	183	216	77	129.3	0.557	346.1	273.1	134.9	235.0	4.1	274.1	28.4	122.9	130.6	165	134.6	8
1050	56,600	2,900	200	235	89	181.4	0.907	388.9	309.1	153.2	254.0	5.1	305.8	38.1	140.7	147.3	183	152.4	9
1055	74,000	2,650	220	266	102	251.7	1.130	425.4	349.5	168.1	279.4	5.1	334.3	38.1	158.0	172.7	203	177.8	9
1060	90,400	2,450	244	290	115	-	1.700	457.2	385.1	188.2	304.8	6.6	366.0	25.4	169.2	186.4	229	193.0	10
1070	135,000	2,150	289	340	127	-	2.270	527.0	453.6	220.7	355.6	8.4	424.9	28.4	195.6	220.2	267	228.6	13

* Coupling Weight is without Bore Machining

G52 Type (Large)

Large Flanged Sleeve Single Engagement

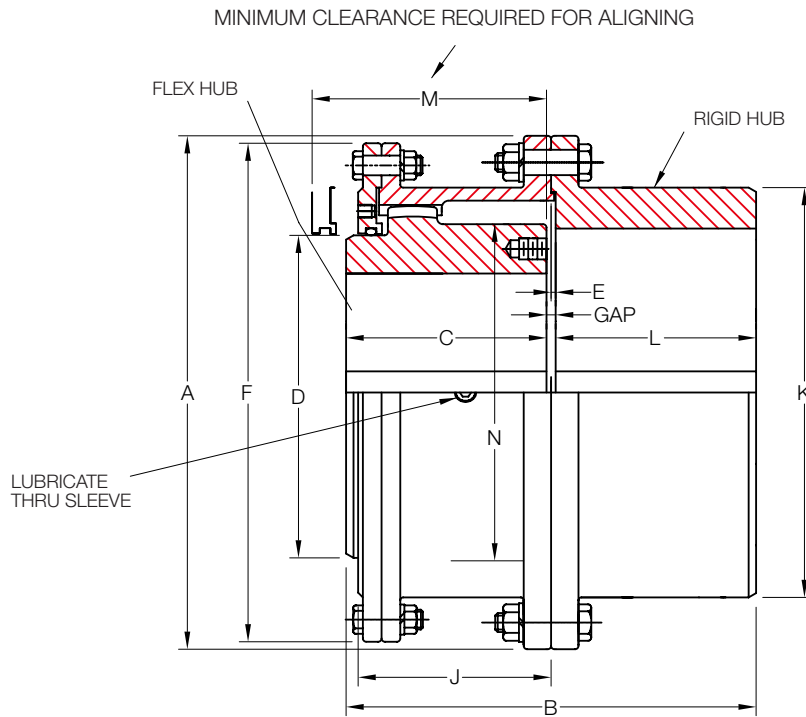

※ IMPORTANT : When couplings are mounted on a floating shaft, do not exceed allowable shaft speed for the assembly.

Size	Torque Rating (Nm)	Allow Speed RPM	Max Bore		Min Bore (mm)	Cplg Weight (Kg)	Lube Weight (Kg)	Dimensions (Millimeters)											
			Flex (mm)	Rigid (mm)				A	B	C	D	E	F	J	K	L	M	N	GAP
1080	170,000	1,750	266	340	101.60	699	5	590.6	511.0	249.4	355.6	8.1	571.5	242.8	450.8	248.9	300.0	368.3	13
1090	226,000	1,550	290	380	114.30	984	6	660.4	566.4	276.4	393.7	8.1	641.4	265.2	508.0	275.8	327.2	419.1	14
1100	310,000	1,450	320	400	127.00	1,252	8	711.2	625.3	304.8	444.5	9.7	698.5	293.6	530.4	304.8	355.6	469.9	16
1110	413,000	1,330	373	440	139.70	1,637	9	774.7	682.2	333.2	495.3	9.7	749.3	322.3	584.2	333.2	384.0	520.7	16
1120	555,000	1,200	400	483	152.40	2,077	11	838.2	720.6	352.6	546.1	9.7	825.5	341.4	647.7	352.3	403.4	571.5	16
1130	719,000	1,075	440	500	165.10	2,572	17	911.4	761.7	371.3	584.2	9.7	886.0	362.0	708.2	371.3	434.8	609.6	19
1140	911,000	920	460	535	177.80	3,062	17	965.2	805.9	393.2	635.0	9.7	939.8	378.0	749.3	393.7	457.2	660.4	19
1150	1,100,000	770	490	580	190.50	3,751	21	1,028.7	857.2	419.1	685.8	9.7	1,003.3	407.9	812.8	419.1	482.6	711.2	19
1160	1,310,000	650	525	630	254.00	4,631	22	1,111.2	908.3	441.3	736.6	12.7	1,085.8	419.1	886.0	441.5	501.6	762.0	25
1180	1,660,000	480	600	710	285.75	6,069	25	1,219.2	939.8	457.2	838.2	12.7	1,193.8	434.8	993.6	457.2	520.7	863.6	25
1200	2,140,000	370	660	780	371.50	8,482	34	1,358.9	1,098.6	536.6	927.1	12.7	1,308.1	514.4	1,095.2	536.4	635.0	965.2	25
1220	2,720,000	290	725	890	349.25	11,680	54	1,511.3	1,196.8	584.2	1,016.0	12.7	1,473.2	565.2	1,244.6	584.2	685.8	1,066.8	28

* Coupling Weight is without Bore Machining

G52 Type

Standard Flanged Sleeve Single Engagement Floating Shaft

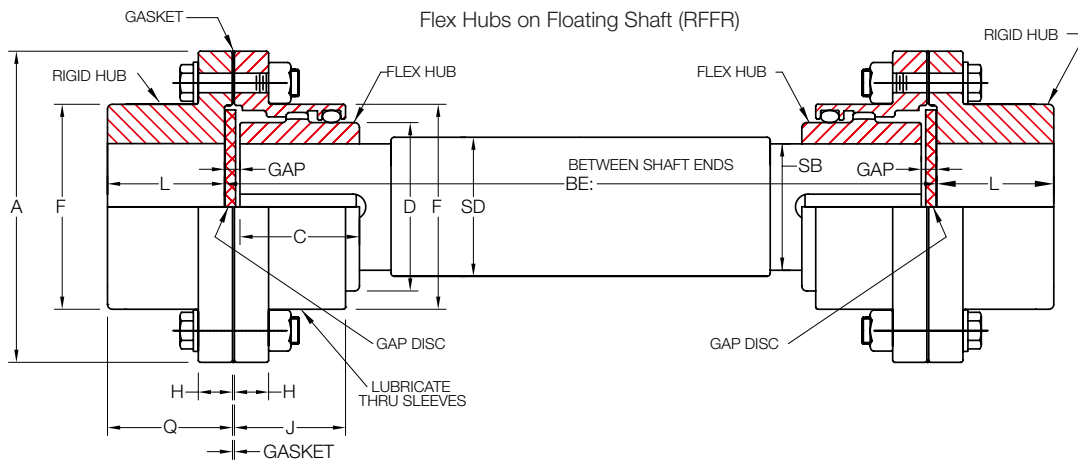

Size	Max Bore		Min Bore (mm)	Cplg Weight		Lube Weight (Kg)	Dimensions (Millimeters)		
	Flex (mm)	Rigid (mm)		G51 (Kg)	G52 (Kg)		A	BE Min	
								RFFR	FRRF
1010	50	65	13	4.08	4.54	0.0227	115.9	133	92
1015	65	80	20	8.16	9.07	0.0408	152.4	159	105
1020	78	98	26	13.6	15.9	0.0680	177.8	197	129
1025	98	118	32	24.9	27.2	0.1180	212.7	241	162
1030	111	140	39	38.6	43.1	0.1810	239.7	279	189
1035	134	163	51	61.2	68.0	0.2720	279.4	324	219
1040	160	196	64	90.7	99.8	0.4670	317.5	419	248
1045	183	216	77	129.3	136.0	0.5570	346.1	508	281
1050	200	235	89	181.4	195.0	0.9070	388.9	533	316
1055	220	266	102	251.7	263.0	1.1300	425.4	572	367
1060	244	290	115	-	324.0	1.7000	457.2	597	397
1070	289	340	127	-	508.0	2.2700	527.0	673	470

G52 Type

Standard Flanged Sleeve Single Engagement Floating Shaft

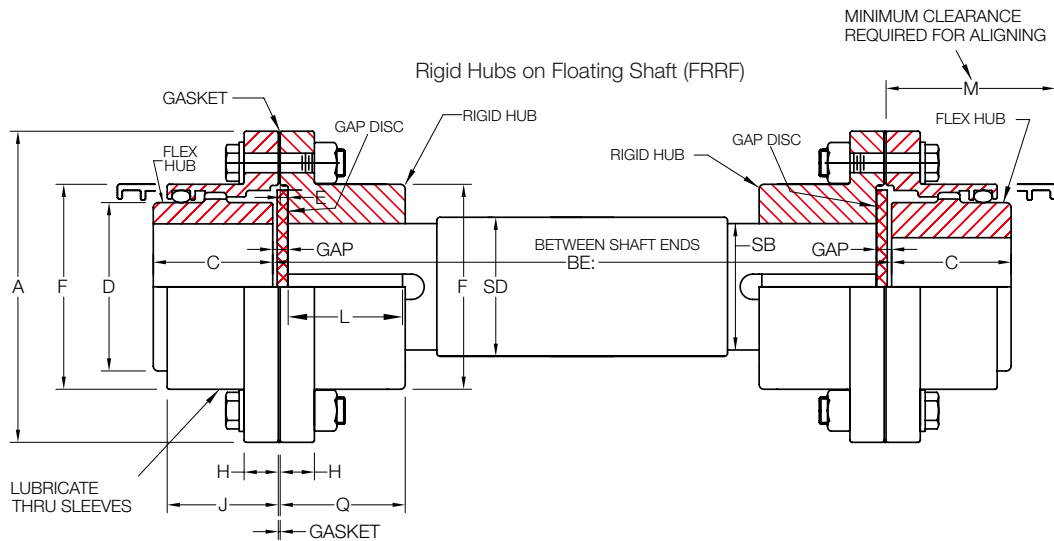

Size	Dimensions (Millimeters)									
	C	D	E	F	H	J	L	M	Q	GAP
1010	42.9	68.6	2.5	83.8	14.0	38.9	39.6	48	42.2	4
1015	49.3	86.4	2.5	105.2	19.0	47.8	46.2	56	48.8	4
1020	62.0	105.2	2.5	126.5	19.0	59.4	58.4	69	61.0	4
1025	77.0	130.6	2.5	154.9	21.8	71.6	73.7	81	76.2	5
1030	91.2	152.4	2.5	180.3	21.8	83.8	87.9	94	90.4	5
1035	106.4	177.8	2.5	211.3	28.4	97.5	102.1	107	104.6	6
1040	120.6	209.6	4.1	245.4	28.4	111.3	115.3	122	119.4	7
1045	134.9	235.0	4.1	274.1	28.4	122.9	130.8	135	134.6	8
1050	153.2	254.0	5.1	305.8	38.1	140.7	147.3	152	152.4	9
1055	168.1	279.4	5.1	334.3	38.1	158.0	172.7	173	177.8	9
1060	188.2	304.8	6.6	366.0	25.4	169.2	186.4	183	193.0	10
1070	220.7	355.6	8.4	424.9	28.4	195.6	220.2	208	228.6	13

* Coupling Weight is without Bore Machining

* Lubrication Weight is per Coupling

KSS Type

Standard Flanged Sleeve Double Engagement

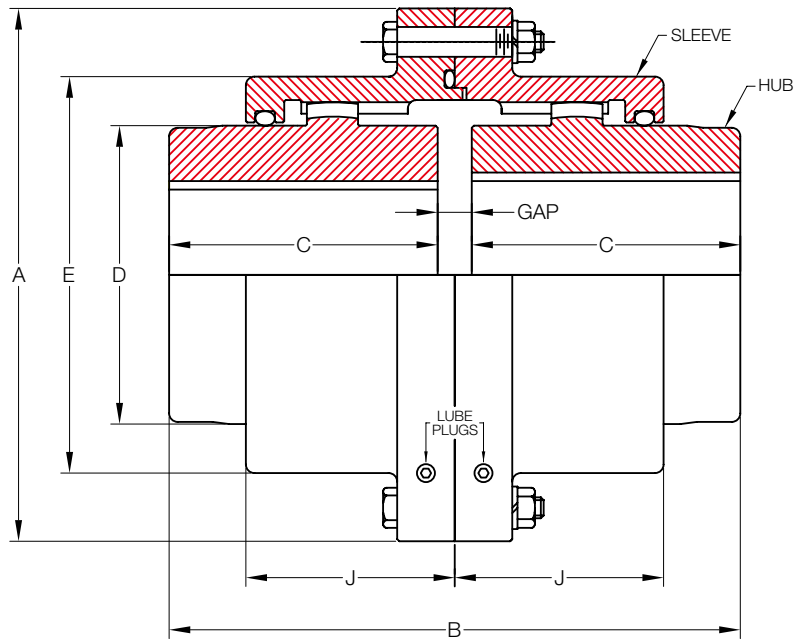

Size	Torque Rating (Nm)	Allow Speed RPM	Max Bore (mm)	Min Bore (mm)	Cplg Weight (Kg)	Lube Weight (Kg)	Dimensions (Millimeters)						KSSH Torque (Nm)	
							A	B	C	D	E	J		GAP
112	560	4,000	40	16	4.3	0.05	112	108	50	58	79	40	8	960
125	1,050	4,000	50	31	6.6	0.06	125	134	63	70	92	43	8	1,650
140	1,510	4,000	56	31	9.3	0.09	140	150	71	80	107	47	8	2,490
160	2,310	4,000	65	31	14.0	0.12	160	170	80	95	120	52	10	3,900
180	3,550	4,000	75	45	19.0	0.15	180	190	90	105	134	56	10	5,940
200	5,060	3,810	85	45	26.0	0.20	200	210	100	120	149	61	10	8,290
224	7,350	3,410	100	51	39.0	0.31	224	236	112	145	174	65	12	14,140
250	9,920	3,050	115	51	55.0	0.45	250	262	125	165	200	74	12	20,450
280	17,170	2,720	135	51	81.0	0.59	280	294	140	190	224	82	14	29,170
315	27,070	2,420	160	112	129.0	0.94	315	356	170	225	260	98	16	38,270
355	39,880	2,150	180	125	177.0	1.11	355	396	190	250	288	108	16	56,450
400	56,000	1,900	200	140	242.0	1.70	400	418	200	285	329	114	18	88,890

* Coupling Weight is without Bore Machining

KCC Type (Large)

Large Flanged Sleeve Double Engagement

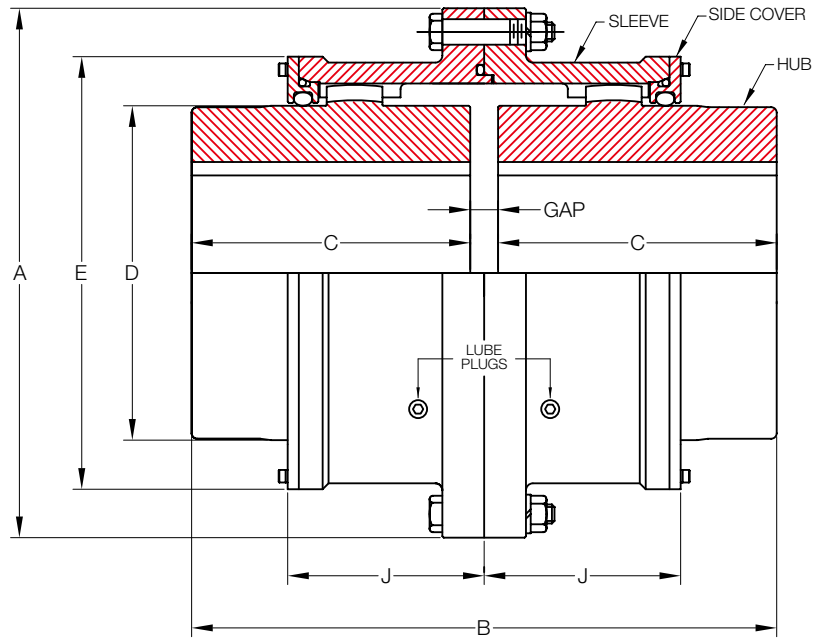

Size	Torque Rating (Nm)	Allow Speed RPM	Max Bore (mm)	Min Bore (mm)	Cplg Weight (Kg)	Lube Weight (Kg)	Dimensions (Millimeters)						KCH Torque (Nm)	
							A	B	C	D	E	J		GAP
450	93,100	1,690	205	140	298	2.11	450	418	200	290	372	151	18	135,240
500	127,400	1,520	236	170	446	3.23	500	494	236	335	425	168	22	225,400
560	203,840	1,360	275	190	642	3.91	560	552	265	385	475	187	22	337,120
630	308,700	1,210	325	224	1,010	5.70	630	658	315	455	548	213	28	458,640
710	449,820	1,070	360	250	1,440	7.99	710	738	355	510	622	242	28	634,060
800	642,880	950	405	280	2,030	11.01	800	832	400	570	690	267	32	862,400
900	915,320	840	475	315	3,030	14.40	900	932	450	670	792	295	32	1,215,200
1000	1,254,400	760	510	355	4,120	19.50	1,000	1,040	500	720	858	322	40	1,646,400
1120	1,764,000	682	600	400	5,920	26.30	1,120	1,160	560	840	990	360	40	2,254,000
1250	2,450,000	610	710	500	9,410	38.20	1,250	1,460	710	960	1,126	399	40	3,067,400

* Coupling Weight is without Bore Machining

KSE Type

Standard Flanged Sleeve Single Engagement

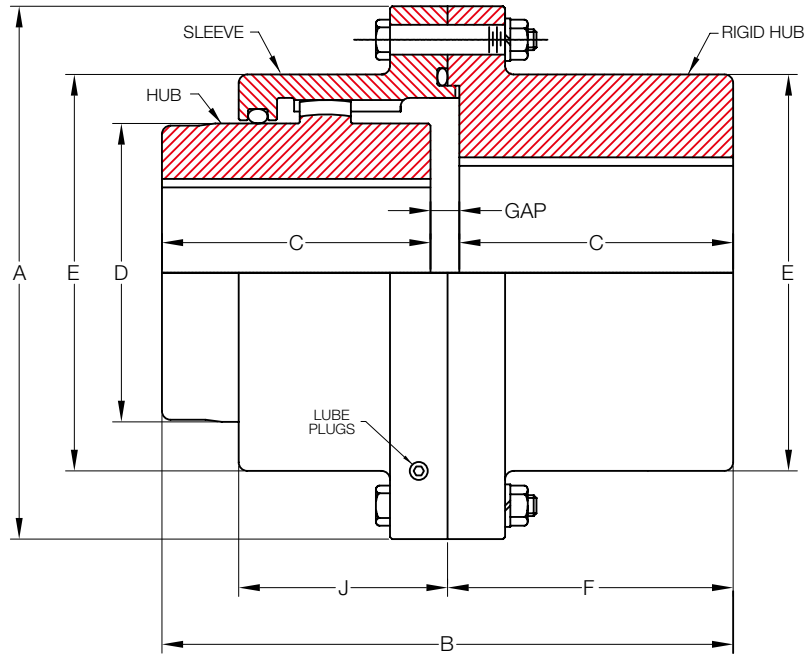

Size	Torque Rating (Nm)	Allow Speed RPM	Max Bore		Min Bore (mm)	Cplg Weight (Kg)	Lube Weight (Kg)	Dimensions (Millimeters)								KSEH Torque (Nm)
			Flex (mm)	Rigid (mm)				A	B	C	D	E	F	J	GAP	
112	560	4,000	40	50	16	4.6	0.04	112	108	50	58	79	54	40	8	960
125	1,050	4,000	50	56	31	6.7	0.05	125	134	63	70	92	67	43	8	1,650
140	1,510	4,000	56	63	31	9.3	0.07	140	150	71	80	107	75	47	8	2,490
160	2,310	4,000	65	75	31	14.0	0.09	160	170	80	95	120	85	52	10	3,900
180	3,550	4,000	75	80	45	19.0	0.12	180	190	90	105	134	95	56	10	5,940
200	5,060	3,810	85	95	45	26.0	0.15	200	210	100	120	149	105	61	10	8,290
224	7,350	3,410	100	105	51	38.0	0.25	224	236	112	145	174	118	65	12	14,140
250	9,920	3,050	115	125	51	56.0	0.35	250	262	125	165	200	131	74	12	20,450
280	17,170	2,720	135	150	51	83.0	0.48	280	294	140	190	224	147	82	14	29,170
315	27,070	2,420	160	180	112	135.0	0.77	315	356	170	225	260	178	98	16	38,270
355	39,880	2,150	180	200	125	184.0	0.94	355	396	190	250	288	198	108	16	56,450
400	56,000	1,900	200	236	140	261.0	1.36	400	418	200	285	329	209	114	18	88,890

* Coupling Weight is without Bore Machining

KCE Type (Large)

Large Flanged Sleeve Single Engagement

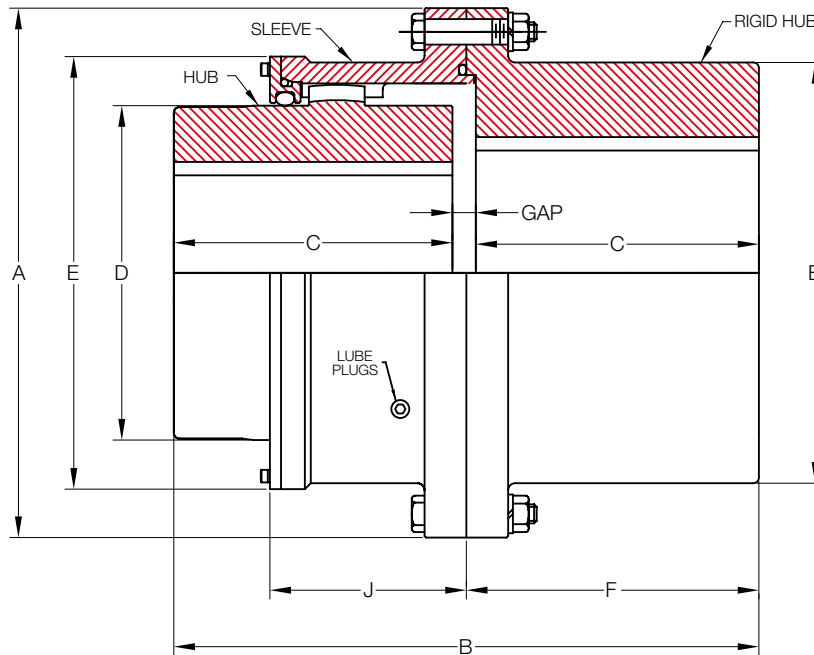

Size	Torque Rating (Nm)	Allow Speed RPM	Max Bore (mm)		Min Bore (mm)	Cplg Weight (Kg)	Lube Weight (Kg)	Dimensions (Millimeters)								KCEH Torque (Nm)
			Flex (mm)	Rigid (mm)				A	B	C	D	E	F	J	GAP	
450	93,100	1,690	205	250	140	304	1.79	450	418	200	290	372	209	151	18	135,240
500	127,400	1,520	236	265	170	458	2.64	500	494	236	335	425	247	168	22	225,400
560	203,840	1,360	275	300	190	664	3.23	560	552	265	385	475	276	187	22	337,120
630	308,700	1,210	325	355	224	1,020	4.93	630	658	315	455	548	329	213	28	458,640
710	449,820	1,070	360	400	250	1,460	6.63	710	738	355	510	622	369	242	28	634,060
800	642,880	950	405	450	280	2,090	9.35	800	832	400	570	690	416	267	32	862,400
900	915,320	840	475	510	315	3,020	11.90	900	932	450	670	792	466	295	32	1,215,200
1000	1,254,400	760	510	570	355	4,130	17.00	1,000	1,040	500	720	858	520	322	40	1,646,400
1120	1,764,000	682	600	640	400	5,970	22.10	1,120	1,160	560	840	990	580	360	40	2,254,000
1250	2,450,000	610	710	800	500	9,820	31.40	1,250	1,460	710	960	1,126	730	399	40	3,067,400

* Coupling Weight is without Bore Machining

KSP Type

Standard Flanged Sleeve Spacer

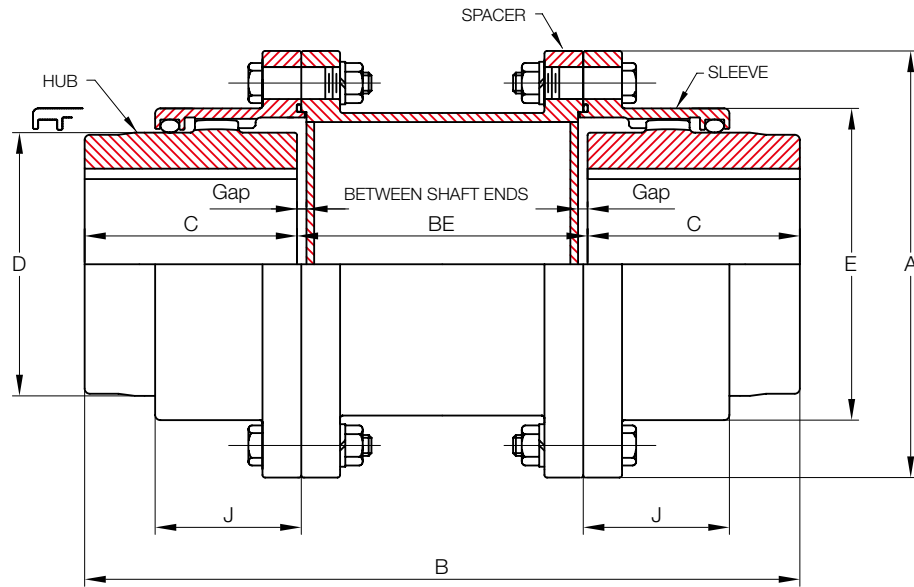

Size	Torque Rating (Nm)	Allow Speed RPM	Max Bore (mm)	Min Bore (mm)	Lube Weight (Kg)	Dimensions (Millimeters)									KSPH Torque (Nm)
						A	BE	B	C	D	E	F	J	GAP	
112	560	4,000	40	16	0.05	112	CUSTOM	2C + BE	50	58	79	54	40	8	960
125	1,050	4,000	50	31	0.06	125			63	70	92	67	43	8	1,650
140	1,510	4,000	56	31	0.09	140			71	80	107	75	47	8	2,490
160	2,310	4,000	65	31	0.12	160			80	95	120	85	52	10	3,900
180	3,550	4,000	75	45	0.15	180			90	105	134	95	56	10	5,940
200	5,060	3,810	85	45	0.20	200			100	120	149	105	61	10	8,290
224	7,350	3,410	100	51	0.31	224			112	145	174	118	65	12	14,140
250	9,920	3,050	115	51	0.45	250			125	165	200	131	74	12	20,450
280	17,170	2,720	135	51	0.59	280			140	190	224	147	82	14	29,170
315	27,070	2,420	160	112	0.94	315			170	225	260	178	98	16	38,270
355	39,880	2,150	180	125	1.11	355			190	250	288	198	108	16	56,450
400	56,000	1,900	200	140	1.70	400			200	285	329	209	114	18	88,890

* Coupling Weight is without Bore Machining
 * Refer to KCP for size 450 ~ 1250

Gear Couplings

Installation

KCP Gear Couplings are designed to provide a mechanical connection between the rotating shafts of mechanical equipment, using gear mesh accommodate inherent misalignment while transmitting the power and torque between the connected shaft.

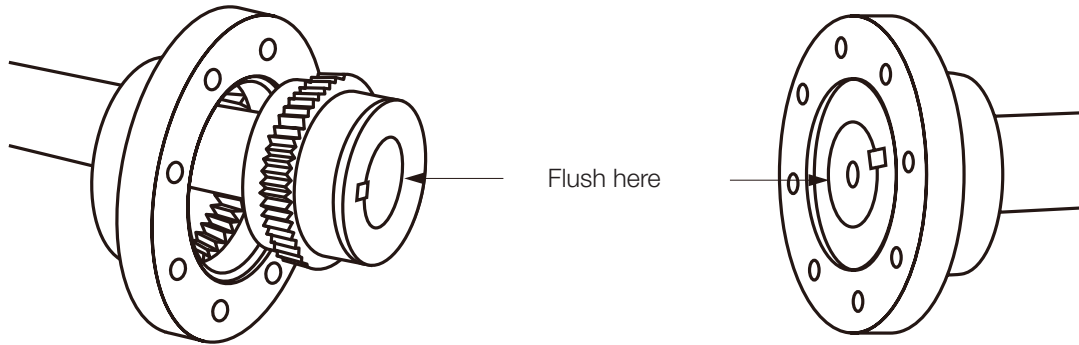

1) Mount Flanged Sleeves, Seals and Hub

- Examine the coupling assembly to insure there is no visible damage.
- Clean the hub bores and shafts using lint free cloth. Remove any nicks or burrs.
- When assembled, the keys should have a close side to side fit in the keyways in the hub and shaft with a slight clearance over the top of the keys.
- Place the flanged sleeves with oil rings on shafts before mounting flex hubs.

2) Straight Bore with Clearance / Slip Fit

- Install the keys in the shaft.
- Check to be sure that the set screws in the hub do not protrude into the keyway or the bore. Remove or back out the set screw to provide clearance during assembly.
- Slide the hub up the shaft to the desired axial position.
- Assemble and tighten the set screws using a calibrated torque wrench.

3) Straight Bore with interference Fit

- Accurately measure the bore and shaft diameters to assure proper fit.
- Install the keys in the shaft.
- heat the hub (135°C) in an oven until the bore is efficiently larger than the shaft.
- When the hub expanded, install it on the shaft to the desired axial position.

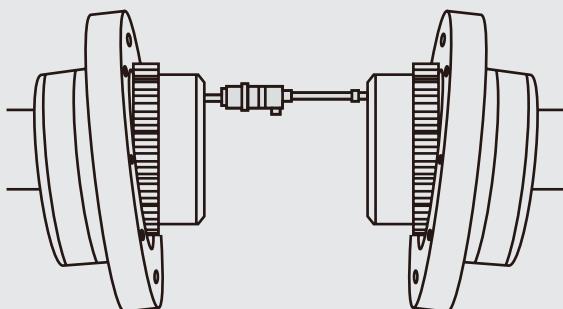

4) Taper Bore

- Check for acceptable contact pattern between the hub and the shaft.
- Put the hub on the shaft, keeping the keyways aligned.
- Lightly tap the face of the hub with a soft mallet. The resultant position will provide a starting point for the hub axial draw up.
- Use a depth micrometer to measure the distance from the shaft end to the hub face, and record the dimension.
- Mount a dial indicator to read axial hub advancement. Alternatively, the indicator can be positioned to contact the end of the hub.
- Remove the hub and install the keys in the shaft.
- Heat the hub (177 °C) in an oven until the bore is sufficiently larger than the shaft. Do not exceed 260 °C.
- When the hub expanded, install it quickly on the shaft to the "zero" set point. Continue to advance the hub up the taper to the desired axial position.

5) Shaft Alignment

- Use an inside micrometer or a spacer bar equal in thickness and at 90° intervals to measure the distance between hubs to gap.
- The "Angular Misalignment" value is the maximum difference between the measurements X and Y taken at opposite ends of the flanges.

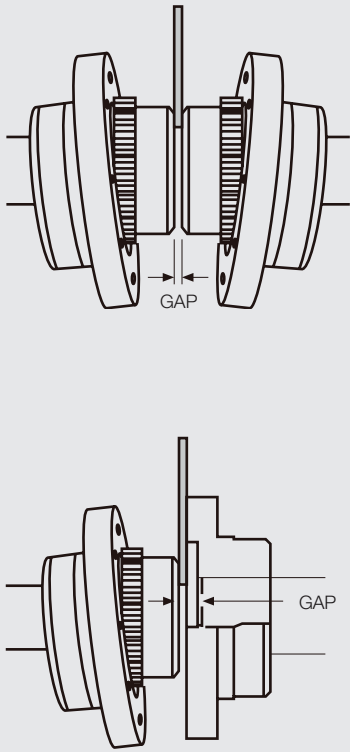

6) Sleeve Installation

- Insert gasket between flanges and gap disc into counter bore of each rigid hub for floating shaft assemblies, and bolt flanges together.
- Check the alignment of the coupling. Determine "W" by measuring distances "W"max and "W"min between flex hub and sleeve using a depth micrometer or feeler gauges. The difference between "W"max and "W"min must not exceed the "W" value.

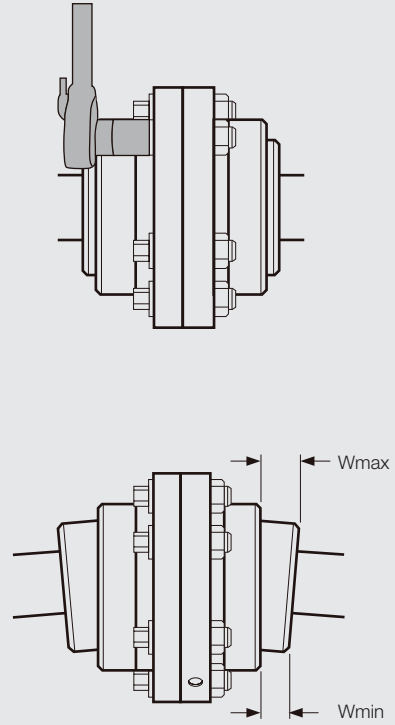

Annual Maintenance

1. Check alignment. If the maximum operating misalignment values are exceeded, realign the coupling.
2. Inspect oil-ring and gasket to determine if replacement is required.
3. Re-lubricate coupling if using general purpose grease until an excess appears at an open hole.

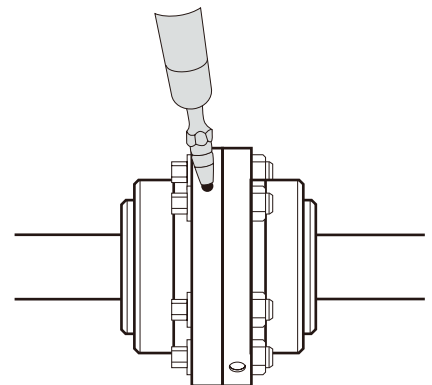

Gear Couplings

Alignment Data

To improve the service life of the coupling, shafts should be aligned to minimize deflection of the flexing elements. Shaft alignment is required in the axial, parallel, and angular directions, with each of these values not to exceed the recommended installation limits. Shaft alignment can be measured using various established methods, including Laser Alignment, Reverse Dial Indicator, and Rim and Face.

Parallel Misalignment

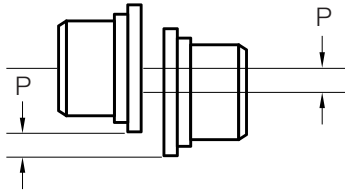

Angular Misalignment

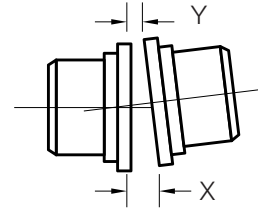

Misalignment Capacity

Size	Recommended Installation		Operating		Fastener Tightening Torque Values (Nm)
	Parallel Offset-P Max (mm)	Angular (X-Y) Max (mm)	Parallel Offset-P Max (mm)	Angular (X - Y) Max (mm)	
1010G	0.05	0.15	0.66	1.80	12
1015G	0.08	0.18	0.86	2.26	42
1020G	0.08	0.23	1.02	2.74	102
1025G	0.10	0.28	1.27	3.43	203
1030G	0.13	0.33	1.52	3.99	203
1035G	0.15	0.38	1.83	4.65	339
1040G	0.18	0.46	2.13	5.49	339
1045G	0.20	0.51	2.39	6.15	339
1050G	0.23	0.56	2.72	6.65	339
1055G	0.28	0.61	3.12	7.32	339
1060G	0.28	0.66	3.35	9.98	339
1070G	0.33	0.79	3.94	9.32	339
1080G	0.41	0.81	2.46	4.83	-
1090G	0.43	0.91	2.64	5.49	-
1100G	0.48	1.02	2.97	6.15	-
1110G	0.56	1.14	3.30	6.81	-
1120G	0.58	1.24	3.51	7.49	-
1130G	0.61	1.32	3.61	7.98	-
1140G	0.64	1.45	3.81	8.64	-
1150G	0.69	1.55	4.17	9.32	-
1160G	0.71	1.60	4.37	10.97	-
1180G	0.74	1.83	4.22	9.65	-
1200G	0.89	2.03	5.28	12.14	-
1220G	0.99	2.21	5.87	13.31	-

Puller Holes

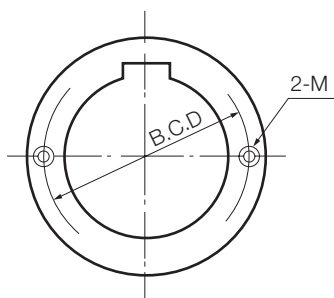

Size	B.C.D (mm)	Bolt
1010	52.32	M10 x 1.5 x 13
1015	69.85	M10 x 1.5 x 13
1020	88.90	M10 x 1.5 x 13
1025	112.78	M10 x 1.5 x 13
1030	128.52	M10 x 1.5 x 13
1035	162.40	M12 x 1.75 x 16
1040	180.98	M16 x 2.0 x 20
1045	200.03	M16 x 2.0 x 20
1050	215.90	M20 x 2.5 x 22
1055	238.13	M20 x 2.5 x 22
1060	263.53	M20 x 2.5 x 22
1070	311.15	M24 x 3.0 x 30

Disc Flexible Couplings



KCP Disc Flexible Couplings are designed to obtain the best capacity to weight ratio. They can reliably be used for mechanical power transmission.

Disc Couplings are used in heavy duty, slow to medium speed applications where high starting torque, torque reversals, continuous alternating torques, and/or shock loads are present. Examples include centrifugal pumps, compressors, ventilators, generators, turbines, electric motors, paper machines, machine tools, cooling towers, and printing machines.

The simple form of the Disc Coupling enables quick installation. The center member, generally an open lug type, minimizes the space required for installation while providing sufficient clearance for assembly. The central member provides excellent dynamic balance, which improves the life of the couplings. Disc Couplings are virtually free from periodic maintenance and do not require lubrication. All components are made of SM45C.

The central member is self-centering and does not require limiting devices or axial float devices for the shaft. The units, including blades and fasteners, are supplied as a single set, which reduces the number of loose parts and makes installation and replacement simple.

Disc Flexible Coupling Types

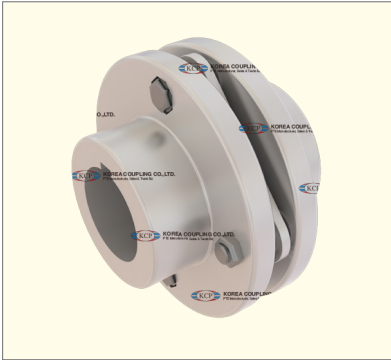

KF3 Type



KF4 Type (Spacer)



KS3 Type



KS4 Type (Spacer)



KE3 Type



KE4 Type (Spacer)



KSC & KEC Type (Spacer)



KSP & KEP Type (Spacer)



K52 Type (Spacer)



K71 Type (Spacer)

KF3 Type

Single Disc Flex with Four Bolts

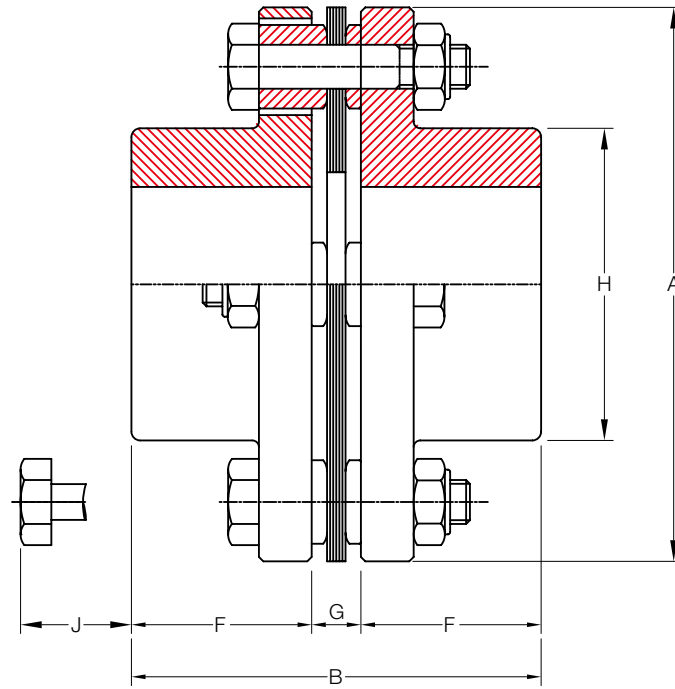

Angular Misalignment = 1.0°
4 Bolt Holes

Size	Torque Rating (Nm)	Allow Speed RPM	Max Bore (mm)	Cplg Weight (Kg)	Bolt Torque (Kg.m)	GD ² (Kg.m ²)	Dimensions (Millimeters)					
							A	B	F	G	H	J
05	33	47,000	23	0.6	0.9	0.0008	67	55.8	25	5.8	33	16
10	90	39,000	32	1.1	0.9	0.0024	81	57.1	25	7.1	46	16
15	176	34,000	35	1.7	2.2	0.0048	93	66.4	29	8.4	51	24
20	245	30,000	42	2.5	2.2	0.0080	104	79.0	34	11.0	61	30
25	421	25,000	50	4.3	4.2	0.0224	126	93.2	41	11.2	71	27
30	774	22,000	58	6.9	7.3	0.0440	143	108.5	48	12.5	84	28
35	1,274	19,000	74	11.3	7.3	0.1080	168	130.0	57	16.0	106	26
40	2,058	16,000	83	16.7	15.9	0.2080	194	145.0	64	17.0	118	30
45	3,332	15,000	95	22.7	15.9	0.3520	214	174.8	76	22.8	137	34
50	4,900	13,000	109	35.4	22.1	0.7200	246	202.0	89	24.0	157	26
55	6,370	11,000	118	52.0	55.3	1.2800	276	230.0	102	26.0	169	42

* Coupling Weight is without Bore Machining

KF4 Type

Double Disc Flex with Four Bolts Spacer Type

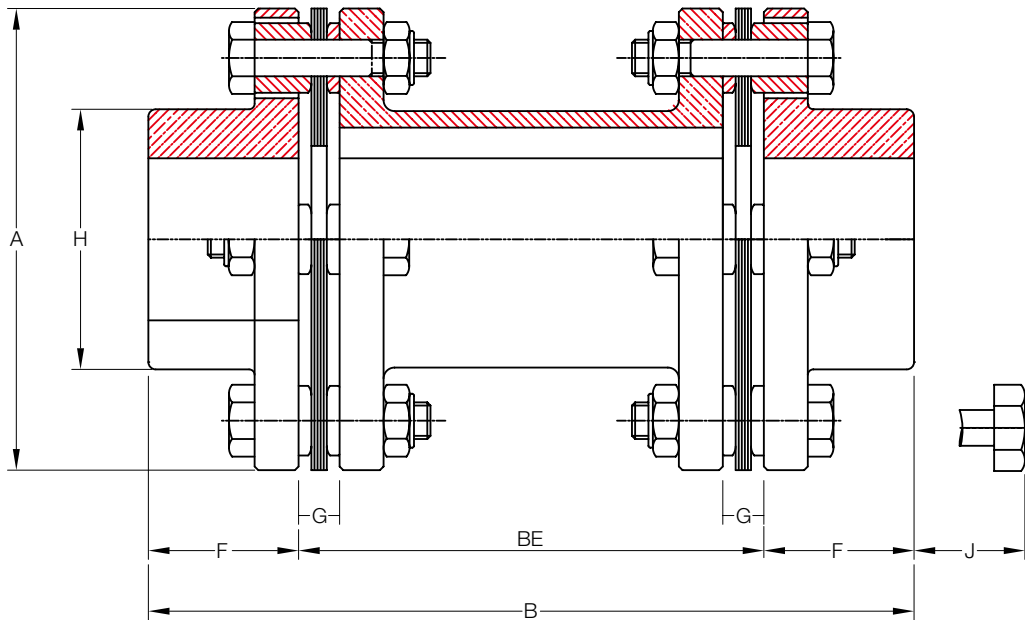

Angular Misalignment = 1.0°
4 Bolt Holes

Size	Torque Rating (Nm)	Allow Speed RPM	Max Bore (mm)	Cplg Weight (Kg)	Bolt Torque (Kg.m)	GD ² (Kg.m ²)	Dimensions (Millimeters)						
							A	B	F	G	H	J	BE
05	33	47,000	23	1.2	0.9	0.0018	67	138.9	25	5.8	33	16	88.9
10	90	39,000	32	1.9	0.9	0.0044	81	138.9	25	7.1	46	16	88.9
15	176	34,000	35	2.9	2.2	0.0084	93	159.6	29	8.4	51	24	101.6
20	245	30,000	42	4.1	2.2	0.0148	104	195.0	34	11.0	61	30	127.0
25	421	25,000	50	7.1	4.2	0.0396	126	209.0	41	11.2	71	27	127.0
30	774	22,000	58	10.8	7.3	0.0800	143	223.0	48	12.5	84	28	127.0
35	1,274	19,000	74	16.3	7.3	0.1680	168	241.0	57	16.0	106	26	127.0
40	2,058	16,000	83	24.7	15.9	0.3400	194	267.7	64	17.0	118	30	139.7
45	3,332	15,000	95	32.5	15.9	0.5600	214	304.4	76	22.8	137	34	152.4
50	4,900	13,000	109	50	22.1	1.1200	246	355.8	89	24.0	157	26	177.8
55	6,370	11,000	118	75	55.3	2.0400	276	381.8	102	26.0	169	42	177.8

* Coupling Weight is without Bore Machining

KS3 Type

Single Disc Flex with Six Bolts

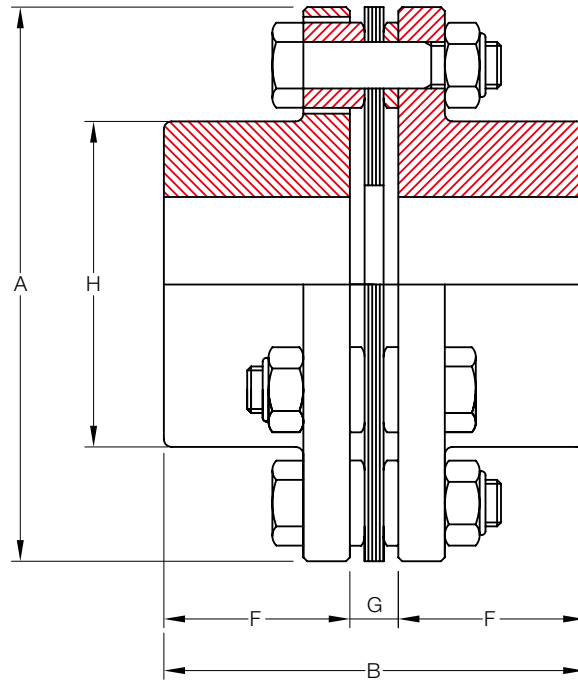

Angular Misalignment = 0.7°
6 Bolt Holes

Size	Torque Rating (Nm)	Allow Speed RPM	Max Bore (mm)	Shaft Line Displacement (mm)	Bolt Torque (Kg.m)	GD ² (Kg.m ²)	Dimensions (Millimeters)				
							A	B	F	G	H
00	568	26,000	51	3.0	2.2	0.04	119	168	54	10.3	74
01	921	23,000	55	3.4	4.2	0.08	137	198	63	11.0	81
02	1,705	19,000	67	3.6	7.3	0.16	161	238	74	12.0	97
03	3,342	17,000	72	4.2	15.9	0.28	180	269	80	14.0	104
04	4,900	15,000	85	4.5	22.1	0.60	212	308	95	17.0	124
05	6,076	11,600	125	3.9	22.1	2.20	276	377	112	17.5	180
10	8,232	11,600	125	3.9	22.1	2.20	276	377	112	19.0	180
15	10,682	10,300	140	4.2	45.0	3.60	308	440	134	19.0	200
20	17,836	9,200	158	4.8	58.0	6.80	346	497	153	22.5	228
25	26,362	8,500	165	5.2	110.0	10.80	375	553	165	28.0	240
30	33,418	7,800	178	5.4	150.0	16.40	410	610	178	31.0	258
35	39,886	7,200	187	5.6	170.0	24.00	445	646	188	31.0	272
40	46,256	6,800	205	6.3	170.0	30.80	470	686	206	34.0	297
45	59,780	6,200	231	6.7	170.0	48.00	511	749	231	35.5	334
50	74,676	5,700	254	7.3	310.0	72.80	556	800	254	37.0	364
55	92,512	5,400	263	7.8	360.0	100.60	587	839	264	37.5	382

KS4 Type

Double Disc Flex with Six Bolts Spacer Type

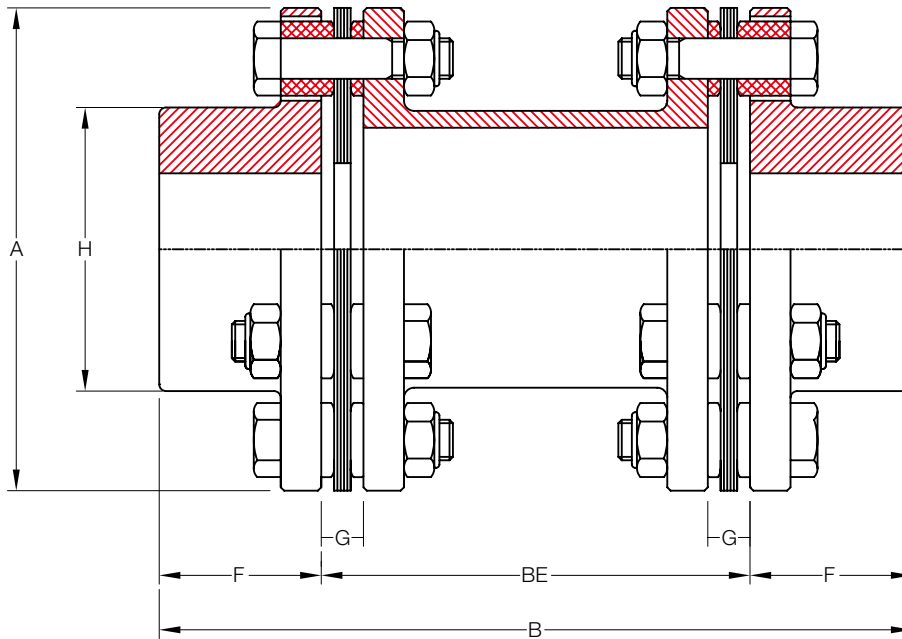

Angular Misalignment = 0.7°
6 Bolt Holes

Size	Torque Rating (Nm)	Allow Speed RPM	Max Bore (mm)	Cplg Weight (Kg)	Shaft Line Displacement (mm)	Bolt Torque (Kg.m)	GD ² (Kg.m ²)	Dimensions (Millimeters)					
								A	B	F	G	H	BE
00	568	26,000	51	6.0	3.0	2.2	0.03	119	168	54	10.3	74	60
01	921	23,000	55	9.1	3.4	4.2	0.06	137	198	63	11.0	81	72
02	1,705	19,000	67	16.9	3.6	7.3	0.14	161	238	74	12.0	97	90
03	3,342	17,000	72	21.6	4.2	15.9	0.26	180	269	80	14.0	104	109
04	4,900	15,000	85	35.1	4.5	22.1	0.59	212	308	95	17.0	124	118
05	6,076	11,600	125	73.3	3.9	22.1	1.80	276	377	112	17.5	180	153
10	8,232	11,600	125	74.3	3.9	22.1	1.90	276	377	112	19.0	180	153
15	10,682	10,300	140	107.8	4.2	45.0	3.70	308	440	134	19.0	200	172
20	17,836	9,200	158	156.1	4.8	58.0	6.70	346	497	153	22.5	228	191
25	26,362	8,500	165	211.8	5.2	110.0	10.60	375	553	165	28.0	240	223
30	33,418	7,800	178	274.5	5.4	150.0	16.50	410	610	178	31.0	258	254
35	39,886	7,200	187	333.3	5.6	170.0	23.90	445	646	188	31.0	272	270
40	46,256	6,800	205	399.2	6.3	170.0	30.70	470	686	206	34.0	297	274
45	59,780	6,200	231	525.3	6.7	170.0	48.00	511	749	231	35.5	334	287
50	74,676	5,700	254	676.3	7.3	310.0	72.90	556	800	254	37.0	364	292
55	92,512	5,400	263	803.4	7.8	360.0	100.60	587	839	264	37.5	382	311

* Coupling Weight is without Bore Machining

KE3 Type

Single Disc Flex with Eight Bolts

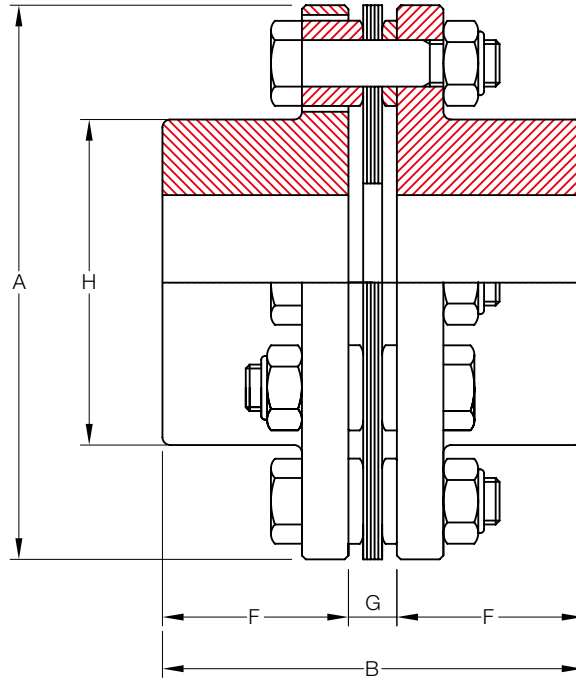

Angular Misalignment = 0.5°
8 Bolt Holes

Size	Torque Rating (Nm)	Allow Speed RPM	Max Bore (mm)	Shaft Line Displacement (mm)	Bolt Torque (Kg.m)	GD ² (Kg.m ²)	Dimensions (Millimeters)				
							A	B	F	G	H
01	3,842	15,000	95	2.1	7.3	0.65	214	228.2	108	12.2	137
03	7,115	13,000	115	2.1	15.9	1.24	246	255.7	121	13.7	165
05	8,967	11,600	125	2.1	22.1	1.80	276	285.5	134	17.5	180
10	10,780	11,600	125	2.1	22.1	1.80	276	287.0	134	19.0	180
15	15,386	10,300	140	2.4	45.0	3.70	308	339.0	160	19.0	200
20	25,578	9,200	158	2.9	58.0	6.80	346	388.5	183	22.5	228
25	37,730	8,500	165	3.1	110.0	10.80	375	424.0	198	28.0	240
30	47,138	7,800	178	3.3	150.0	16.70	410	459.0	214	31.0	258
35	57,036	7,200	187	3.6	170.0	25.0	445	481.0	225	31.0	272
40	64,386	6,800	205	4.0	170.0	31.10	470	528.0	247	34.0	297
45	83,594	6,200	231	4.5	170.0	48.00	511	591.5	278	35.5	334
50	103,194	5,700	254	5.0	310.0	74.40	556	647.0	305	37.0	364
55	128,086	5,400	263	5.2	360.0	101.60	587	671.5	317	37.5	382

* Coupling Weight is without Bore Machining

KE4 Type

Double Disc Flex with Eight Bolts Spacer Type

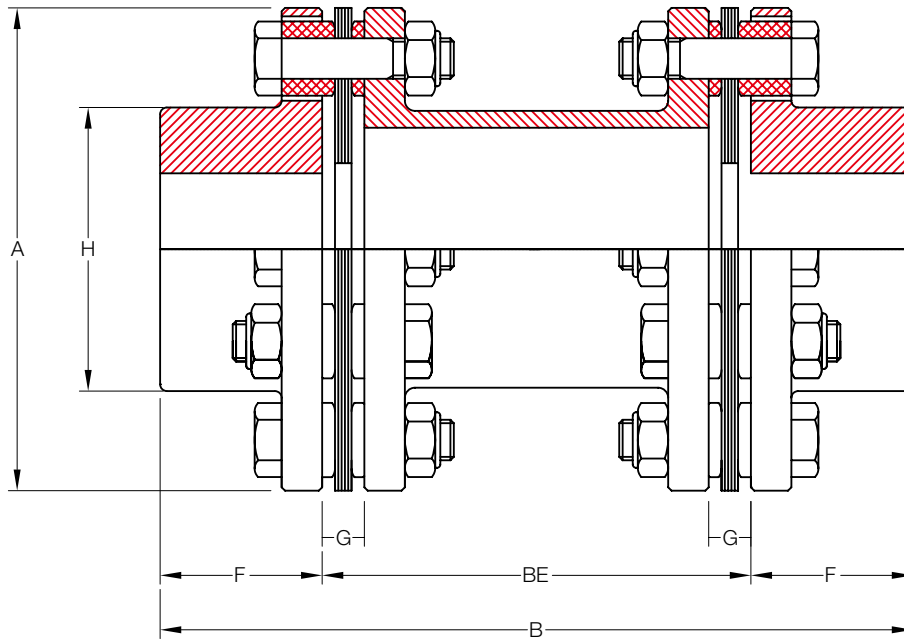

Angular Misalignment = 0.5°
8 Bolt Holes

Size	Torque Rating (Nm)	Allow Speed RPM	Max Bore (mm)	Cplg Weight (Kg)	Shaft Line Displacement (mm)	Bolt Torque (Kg.m)	GD ² (Kg.m ²)	Dimensions (Millimeters)					
								A	B	F	G	H	BE
01	3,842	15,000	95	38.0	2.1	7.3	0.64	214	333	108	12.2	137	117
03	7,115	13,000	115	60.0	2.1	15.9	1.36	246	369	121	13.7	165	127
05	8,967	11,600	125	82.3	2.1	22.1	2.30	276	421	134	17.5	180	153
10	10,780	11,600	125	83.3	2.1	22.1	2.30	276	421	134	19.0	180	153
15	15,386	10,300	140	119.7	2.4	45.0	3.70	308	492	160	19.0	200	172
20	25,578	9,200	158	174.3	2.9	58.0	6.80	346	557	183	22.5	228	191
25	37,730	8,500	165	233.8	3.1	110.0	10.80	375	619	198	28.0	240	223
30	47,138	7,800	178	305.3	3.3	150.0	16.70	410	682	214	31.0	258	254
35	57,036	7,200	187	367.4	3.6	170.0	25.00	445	720	225	31.0	272	270
40	64,386	6,800	205	447.5	4.0	170.0	31.10	470	768	247	34.0	297	274
45	83,594	6,200	231	591.6	4.5	170.0	48.00	511	843	278	35.5	334	287
50	103,194	5,700	254	761.4	5.0	310.0	74.70	556	902	305	37.0	364	292
55	128,086	5,400	263	901.9	5.2	360.0	101.60	587	945	317	37.5	382	311

* Coupling Weight is without Bore Machining

KSC & KEC Type

**Double Disc Flex with Six Bolts
Spacer Type**

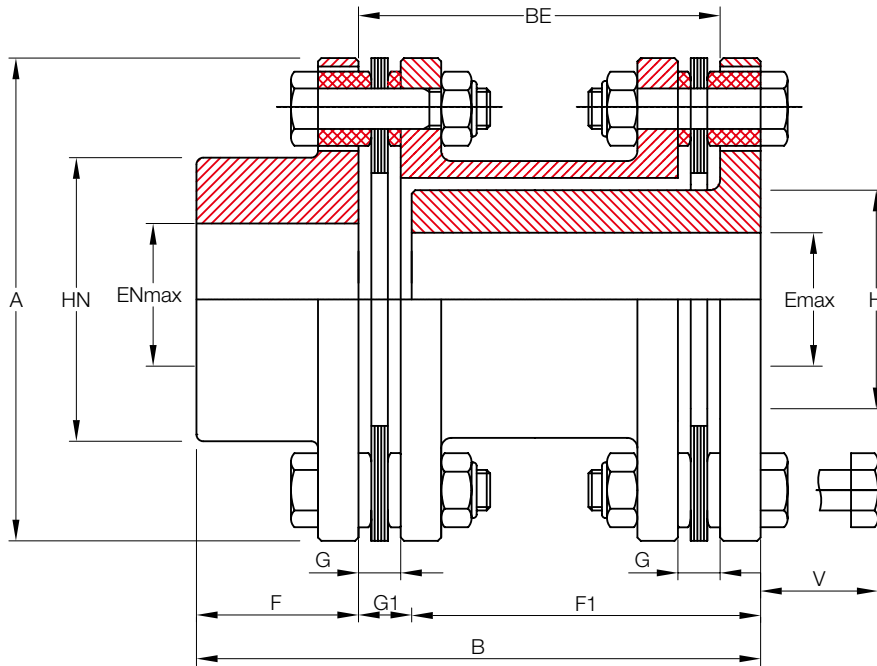

Size	Torque Rating (Nm)	Allow Speed RPM	Max Bore (mm)	Min Bore (mm)	Cplg Weight (Kg)	Axial Deflection (mm)	GD ² (Kg.m ²)	Dimensions (Millimeters)									
								A	B	D(BE)	G	F	F1	G1	HN	H	V
KSC 00	568	26,000	51	40	6.2	3.0	0.04	119	126	60	10.3	54	60	12	74	58	51
KSC 01	921	23,000	56	46	9.5	3.4	0.08	137	147	70	11.0	63	70	14	81	67	55
KSC 02	1,705	19,000	67	52	16.2	3.6	0.12	161	164	75	12.0	74	75	15	97	76	64
KSC 03	3,342	17,000	72	56	21.6	.2	0.28	180	188	90	14.0	80	90	18	104	81	77
KSC 04	4,900	15,000	85	66	35.8	4.5	0.60	212	215	100	17.0	95	100	20	124	96	88

Size	Torque Rating (Nm)	Allow Speed RPM	Max Bore (mm)	Min Bore (mm)	Cplg Weight (Kg)	Axial Deflection (mm)	GD ² (Kg.m ²)	Dimensions (Millimeters)									
								A	B	D(BE)	G	F	F1	G1	HN	H	V
KEC 01	3,842	15,000	95	84	29.8	2.1	0.60	214	216	90	12.2	108	93	15	137	122	77
KEC 03	7,115	13,000	115	98	45.2	2.1	1.12	246	234	95	13.7	121	98	15	165	142	77
KEC 05	8,967	11,600	125	101	60.7	2.1	1.60	276	264	110	17.5	134	105	25	180	147	88
KEC 10	10,780	11,600	125	101	65.1	2.1	1.60	276	264	110	19.0	134	105	25	180	147	88
KEC 15	15,386	10,300	140	118	98.8	2.4	3.32	308	303	120	19.0	160	118	25	200	171	101
KEC 20	25,578	9,200	158	136	141.0	2.9	6.00	346	336	130	22.5	183	127	26	228	197	107
KEC 25	37,730	8,500	165	147	201.0	3.1	9.92	375	374	150	28.0	198	145	31	240	213	128
KEC 30	47,138	7,800	178	159	259.0	3.3	15.20	410	407	165	31.0	214	160	33	258	231	140
KEC 35	57,036	7,200	187	170	315.0	3.6	23.10	445	430	175	31.0	225	170	35	272	245	149
KEC 40	64,386	6,800	205	187	378.0	4.0	28.90	470	457	180	34.0	247	175	35	297	271	157
KEC 45	83,594	6,200	231	208	489.0	4.5	42.10	511	508	195	35.5	278	190	40	334	302	168
KEC 50	103,194	5,700	254	233	615.0	5.0	65.40	556	540	200	37.0	305	195	40	364	338	174
KEC 55	128,086	5,400	263	240	739.0	5.2	90.10	587	562	210	37.5	317	205	40	382	348	180

* Coupling Weight is without Bore Machining

KSP & KEP Type

**Double Disc Flex with Six Bolts
Spacer Type
Plug - In**

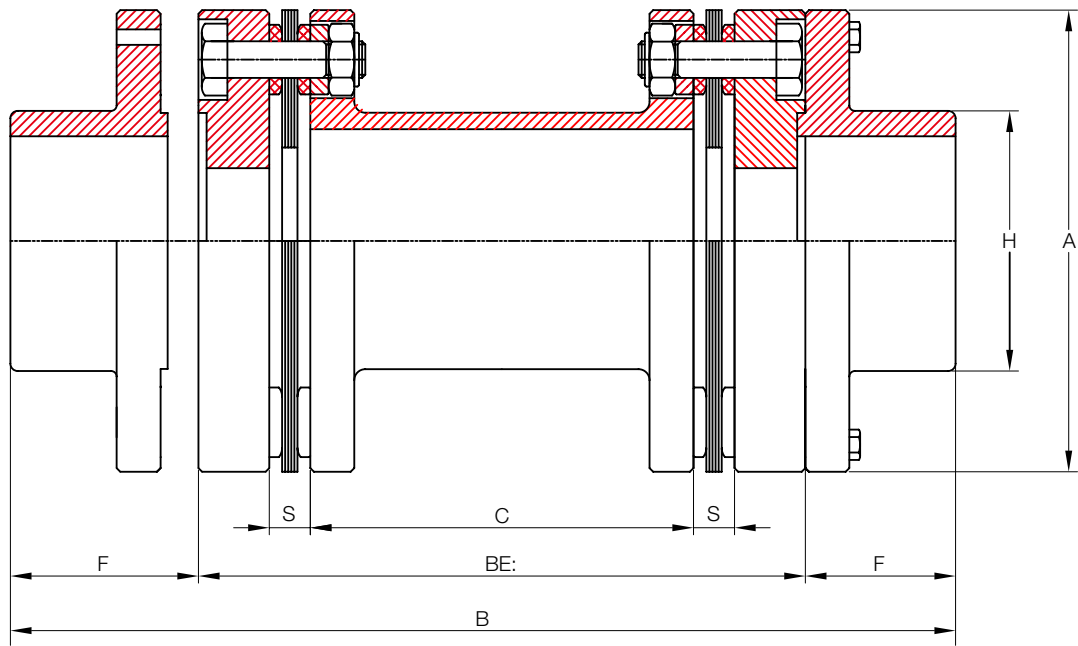

Size	Torque Rating (Nm)	Allow Speed RPM	Max Bore (mm)	Cplg Weight (Kg)	Axial Deflection (mm)	GD ² (Kg.m ²)	Dimensions (Millimeters)						
							A	B	C	BE	S	F	H
KSP 00	568	26,000	68	8.4	3.0	0.072	128	256	90	120	15	68	100
KSP 01	921	23,000	78	11.5	3.4	0.128	146	276	84	120	18	78	112
KSP 02	1,705	19,000	96	21.4	3.6	0.340	170	322	98	140	21	96	138
KSP 03	3,342	17,000	104	33.7	4.2	0.684	198	378	116	170	27	104	150
KSP 04	4,900	15,000	123	51.7	4.5	1.420	226	426	118	180	31	123	178
KSP 05	6,076	11,600	160	96.8	3.9	4.092	282	540	158	220	31	160	232
KSP 10	8,232	11,600	158	100.0	3.9	4.880	294	540	158	220	31	160	228
KSP 15	10,682	10,300	182	153.0	4.2	8.952	330	614	174	250	38	182	264
KSP 20	17,836	9,200	206	216.0	4.9	15.240	366	692	196	280	42	206	300
KSP 25	26,362	8,500	224	309.0	5.2	30.672	422	768	220	320	50	224	324
KSP 30	33,418	7,800	244	395.0	5.4	43.532	452	848	250	360	55	244	354
KSP 35	39,886	7,200	260	505.0	5.6	70.152	498	910	270	390	60	260	376
KSP 40	46,256	6,800	276	576.0	6.3	88.312	522	942	270	390	60	276	400
KSP 45	59,780	6,200	304	749.0	6.7	131.900	564	1,028	288	420	66	304	442

Size	Torque Rating (Nm)	Allow Speed RPM	Max Bore (mm)	Cplg Weight (Kg)	Axial Deflection (mm)	GD ² (Kg.m ²)	Dimensions (Millimeters)						
							A	B	C	BE	S	F	H
KEP 03	7,115	13,000	144	69.9	2.1	2.592	258	468	124	180	28	144	208
KEP 05	8,967	11,600	160	96.8	2.1	4.092	282	540	158	220	31	160	232
KEP 10	10,780	11,600	158	100.0	2.1	4.880	294	540	158	220	31	160	228
KEP 15	15,386	10,300	182	153.0	2.4	8.952	330	614	174	250	38	182	264
KEP 20	25,578	9,200	206	216.0	2.9	15.240	366	692	196	280	42	206	300
KEP 25	37,730	8,500	224	309.0	3.1	30.672	422	768	220	320	50	224	324
KEP 30	47,138	7,800	244	395.0	3.3	43.532	452	848	250	360	55	244	354
KEP 35	57,036	7,200	260	505.0	3.6	70.152	498	910	270	390	60	260	376
KEP 40	64,386	6,800	276	576.0	4.0	88.312	522	942	270	390	60	276	400
KEP 45	83,594	6,200	-	749.0	4.5	131.900	564	1,028	288	420	66	304	442

* Coupling Weight is without Bore Machining

K52 Type

Double Disc Flex Spacer Type

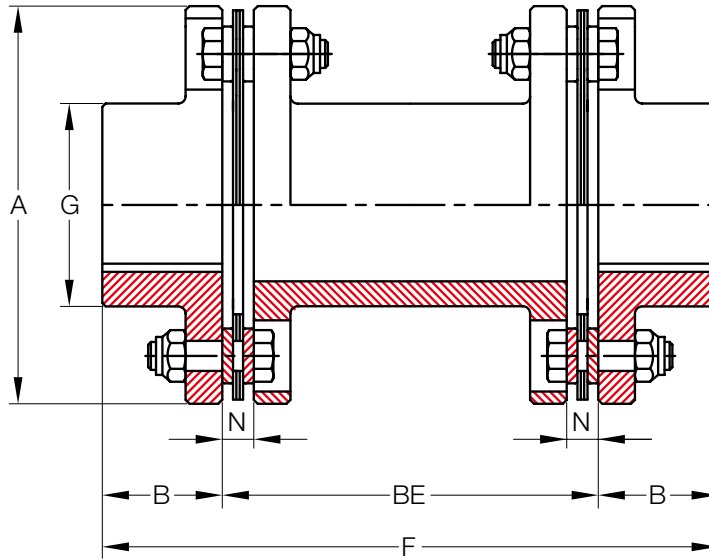

Size	Max Contin. Torque (Nm)	Peak Torque (Nm)	Max Speed (RPM)		Cplg Weight (Kg)	Change of "C" Weight (Kg)	WR ² (Kg.m ²)	Change of "C" WR ² (Kg.m ²)	Axial Capacity (mm)	Max. kW Per 100RPM S.F = 1.0
			Not Balanced RPM	Balanced RPM						
125	305	610	5,000	15,000	2.1	0.003	0.0022	0.00170	±0.91	3.2
162	604	1,208	4,600	15,000	3.3	0.004	0.0046	0.00310	±0.91	6.3
200	1,185	2,371	4,250	15,000	5.6	0.004	0.0128	0.00670	±0.91	12.5
225	1,976	3,951	4,100	14,000	7.3	0.006	0.0178	0.00980	±0.91	20.7
262	3,706	7,413	3,900	13,000	11.8	0.009	0.0401	0.01800	±1.09	38.9
312	5,803	11,605	3,450	11,700	18.8	0.012	0.0878	0.03600	±1.29	60.8
350	7,552	15,105	3,200	10,500	26.6	0.015	0.1540	0.05500	±1.42	79.0
375	11,323	22,646	3,000	9,400	36.3	0.018	0.2660	0.08300	±1.57	118.6
425	15,161	30,323	2,800	8,700	47.2	0.026	0.4040	0.13500	±1.70	158.8
450	16,979	33,958	2,700	8,100	57.7	0.026	0.5760	0.16600	±1.82	178.2
500	27,817	55,633	2,500	7,100	89.0	0.041	1.1120	0.31300	±2.02	291.5
550	37,300	74,599	2,300	6,300	127.6	0.052	2.0190	0.49500	±2.33	390.7
600	48,973	97,945	2,150	5,700	168.0	0.059	3.2770	0.70500	±2.59	512.9
700	76,180	152,359	1,950	5,000	257.4	0.082	6.5250	1.19000	±2.92	798.5
750	94,694	189,388	1,850	4,600	323.2	0.093	9.6850	1.65000	±3.17	992.4
800	121,777	243,554	1,750	4,300	413.6	0.107	15.0500	2.30000	±3.45	1,276.50
850	143,712	287,424	1,600	3,900	503.5	0.107	20.9800	2.30000	±3.65	1,506.10
925	194,626	389,253	1,500	3,600	662.4	0.143	32.6000	4.61000	±3.96	2,039.20
1000	220,140	440,280	-	3,250	853.5	0.161	50.3000	5.83000	±4.36	2,306.90
1100	262,475	524,949	-	3,100	1021.5	0.197	68.9100	9.15000	±4.64	2,750.50
1200	320,050	640,099	-	2,800	1366.5	0.268	110.1600	13.78000	±5.15	3,353.70
1300	382,705	765,410	-	2,600	1661.6	0.268	153.2300	15.55000	±5.53	4,010.60

Size	Max Bore (mm)	Dimensions (Millimeters)						
		A	B	C		F	G	N
				Std	Min			
125	34	94	33	102	-	168	52	7
162	50	110	44	127	52	216	70	7
200	58	138	52	127	67	232	83	9
225	70	145	67	127	70	260	96	9
262	84	168	73	127	82	273	114	12
312	97	198	86	140	95	311	133	13
350	110	221	95	152	106	343	149	14
375	120	246	102	178	117	381	165	15
425	130	267	108	178	125	394	178	16
450	140	287	114	203	136	432	189	18
500	146	327	127	229	153	483	213	20

Size	Max Bore (mm)	Dimensions (Millimeters)						
		A	B	C		F	G	N
				Std	Min			
550	166	367	140	254	175	533	240	23
600	176	406	152	254	191	559	260	25
700	205	464	178	279	217	635	298	30
750	224	503	191	279	235	660	321	32
800	241	546	210	305	255	724	346	34
850	250	584	222	330	273	775	368	36
925	267	635	241	356	292	838	400	38
100	290	699	267	368	-	902	438	43
1100	314	741	286	406	-	978	470	44
1200	339	816	311	432	-	1,054	514	50
1300	376	876	337	457	-	1,130	556	52

K71 Type

**Double Disc Flex with Four, Six & Eight Bolts
Spacer Type**

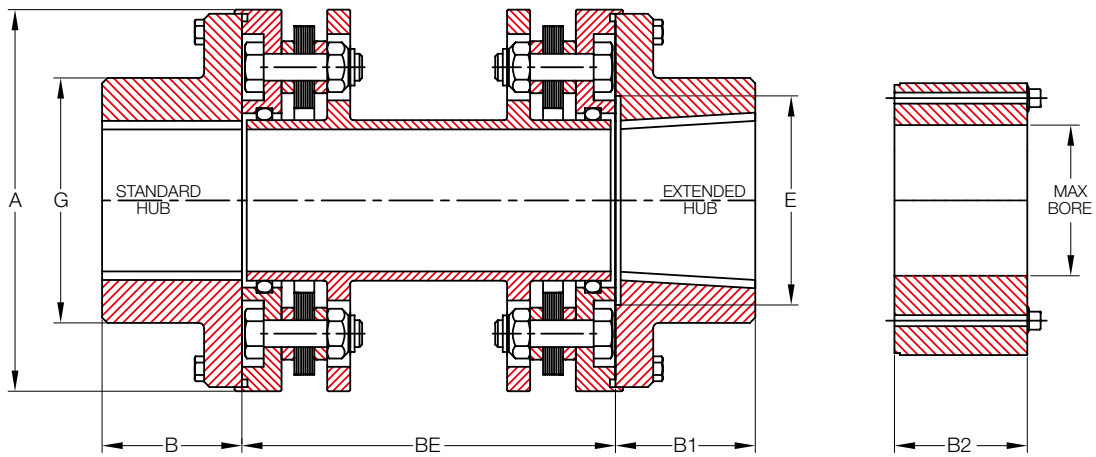

Size	B & B1 Hub Max Bore (mm)	B2 Hub Max Bore (mm)	Dimensions (Millimeters)							
			A	B	B1	B2	C		E Max	G
							Std	Min		
150 (4-Bolt)	39	64	91	33	43	41	89	87	52	59
175 (4-Bolt)	50	73	106	40	52	46	89	87	65	71
225 (6-Bolt)	58	87	125	51	64	52	127	87	78	85
300 (6-Bolt)	81	110	152	67	83	70	127	102	105	113
350 (6-Bolt)	95	120	171	79	95	76	127	124	127	133
375 (6-Bolt)	100	137	194	83	102	83	140	127	135	144
412 (6-Bolt)	110	145	203	92	111	92	178	155	146	155
462 (6-Bolt)	130	166	229	105	127	105	178	178	160	174
512 (6-Bolt)	140	187	255	114	137	114	178	191	179	194
562 (6-Bolt)	156	200	279	127	152	127	203	203	195	213
600 (6-Bolt)	166	220	298	133	162	133	229	229	211	227
225 (8-Bolt)	80	106	152	64	79	78	127	121	106	116
262 (8-Bolt)	95	128	175	78	94	90	178	140	119	132
312 (8-Bolt)	112	145	203	90	109	105	191	152	146	160
350 (8-Bolt)	130	166	227	99	121	114	191	171	165	179
375 (8-Bolt)	144	185	252	113	135	131	191	184	181	202
425 (8-Bolt)	158	203	273	124	149	140	203	191	189	214
450 (8-Bolt)	170	214	294	129	157	152	229	222	213	236
500 (8-Bolt)	196	248	333	151	179	171	279	260	232	267
550 (8-Bolt)	215	-	373	167	198	-	292	292	254	292
600 (8-Bolt)	242	-	416	183	214	-	318	318	298	336
700 (8-Bolt)	258	-	471	211	246	-	368	368	325	373
750 (8-Bolt)	286	-	511	227	262	-	400	400	363	413

Size	Max Contin. Torque (Nm)	Peak Torque (Nm)	Max Speed (RPM)		Cplg Weight (Kg)	Change of "C" Weight (Kg)	WR ² (Kg.m ²)	Change of "C" WR ² (Kg.m ²)	Axial Capacity (mm)	Max. kW Per 100RPM S.F = 1.0
			Not Balanced RPM	Balanced RPM						
150 (4-Bolt)	105	210	9,000	20,800	3.0	0.0018	0.0031	0.00035	±0.1270	1.1
175 (4-Bolt)	184	368	8,300	17,000	4.3	0.0025	0.0060	0.00104	±0.1778	1.9
225 (6-Bolt)	345	691	7,700	16,000	6.4	0.0034	0.0123	0.00288	±0.1905	3.6
300 (6-Bolt)	820	1,639	6,800	14,000	11.8	0.0046	0.0354	0.00760	±2.1590	8.6
350 (6-Bolt)	1,513	3,026	6,200	13,500	19.5	0.0075	0.0758	0.01360	±2.2960	15.8
375 (6-Bolt)	2,179	4,358	5,650	12,000	25.0	0.0077	0.1238	0.01870	±2.4130	22.8
412 (6-Bolt)	2,540	5,080	5,350	11,000	32.2	0.0107	0.1799	0.03340	±2.7940	26.6
462 (6-Bolt)	4,561	9,122	5,000	10,000	45.9	0.0143	0.3248	0.05360	±3.0480	47.8
512 (6-Bolt)	6,209	12,418	4,700	9,200	61.3	0.0186	0.5355	0.08560	±3.3020	65.0
562 (6-Bolt)	9,494	18,988	4,350	8,300	84.4	0.0229	0.8837	0.12000	±3.6830	99.4
600 (6-Bolt)	10,352	20,704	4,150	7,800	103.5	0.0313	1.2436	0.20200	±4.0640	108.4
225 (8-Bolt)	1,976	3,952	7,500	14,000	12.6	0.0068	0.0375	0.01230	±0.9100	20.7
262 (8-Bolt)	3,706	7,412	6,800	12,500	19.5	0.0082	0.0775	0.02250	±1.0900	38.8
312 (8-Bolt)	5,803	11,606	6,200	11,500	30.0	0.0098	0.1697	0.03850	±1.2900	60.8
350 (8-Bolt)	7,552	15,104	5,700	10,500	43.0	0.0134	0.3017	0.06490	±1.4200	79.1
375 (8-Bolt)	11,323	22,646	5,200	9,800	61.0	0.0188	0.5220	0.10600	±1.5700	118.6
425 (8-Bolt)	15,161	30,322	5,000	9,300	77.0	0.0218	0.7654	0.14500	±1.7000	158.8
450 (8-Bolt)	16,979	33,958	4,700	8,700	100.0	0.0284	1.1763	0.20700	±1.8200	177.8
500 (8-Bolt)	27,817	55,634	4,200	7,900	155.0	0.0379	2.3525	0.36200	±2.0200	291.3
550 (8-Bolt)	37,300	74,600	3,900	7,300	216.0	0.0474	4.0759	0.57400	±2.3400	390.6
600 (8-Bolt)	48,973	97,946	3,600	6,800	296.0	0.0545	7.0604	0.79600	±2.5900	512.9
700 (8-Bolt)	76,180	152,360	3,300	6,200	436.0	0.0738	13.1377	1.36000	±2.9200	797.8
750 (8-Bolt)	94,694	189,388	3,100	5,800	564.0	0.0924	20.2538	2.02000	±3.1800	991.7

Tire Couplings



KCP Tire Couplings provide an ideal flexible coupling and include features such as Taper Bush fixing. Tire Couplings create a torsionally elastic coupling and offer a choice of flange combinations to suit most applications. The flanges are available in either Face or hub Taper Bush fitting, or can be bored to size, increasing the versatility for designers and engineers. The couplings can accommodate a standard distance between shaft ends through the addition of a spacer flange. This simple addition can facilitate equipment maintenance.

Tire Couplings are comprised of symmetrical shapes. The symmetry ensures balance and safety while minimizing the existing imbalance in any assembly. Replacing the tire and rubber parts is quick and simple and can be performed without displacing the equipment. This significantly reduces machine downtime. Maintenance costs are also reduced compared to other assemblies because Tire Coupling components do not require lubrication.

The flexible tire provides excellent shock-absorbing properties which reduce vibration and torsional oscillation. By isolating vibrations between machines and motors, workplace noise emissions are considerably reduced, greatly improving the workplace environment. In addition to mechanical isolation, Tire Couplings ensure perfect electrical isolation between shafts, removing a important cause of bearing failure.

Tire Coupling Types



KCS-L Type



KCS-P Type

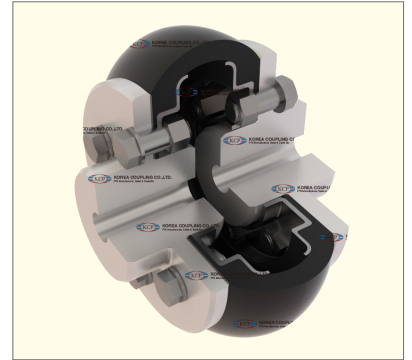

KCS-M Type

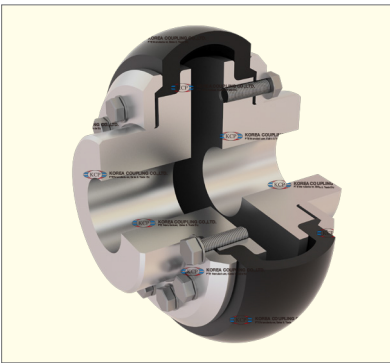

KRB Type



KRF Type

KCS-L Type

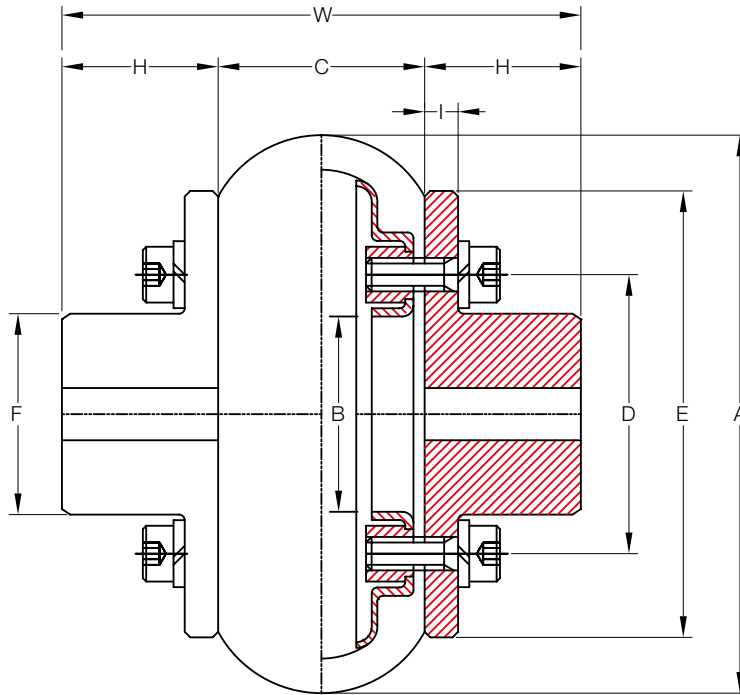

Size	Torque Rating (Nm)	Allow Speed RPM	Max Bore (mm)	Min Bore (mm)	Cplg Weight (Kg)	GD ² (Kg.cm-S ²)	Dimensions (Millimeters)									Hexa Bolt
							A	B	C	D	E	F	H	I	W	
100	50	5,000	22	8	1.1	0.0089	100	35	37	50	82	36	28	6	93	2 x 6 x M6 x 18L
120	98	4,500	28	10	2.0	0.0200	120	45	39	65	106	48	35	6	109	2 x 6 x M8 x 18L
140	147	4,200	35	24	3.0	0.0420	140	52	45	75	118	55	44	7	133	2 x 6 x M10 x 22L
160	216	4,000	42	24	4.5	0.0770	160	62	51	85	132	65	53	8	157	2 x 6 x M24 x 70L
185	294	3,600	48	34	6.6	0.1450	185	74	58	100	154	77	60	10	178	2 x 6 x M10 x 22L
220	490	3,200	55	34	11.8	0.3300	220	84	67	112	180	89	69	12	205	2 x 6 x M12 x 25L
265	980	2,600	75	40	21.7	0.9700	265	112	82	140	214	117	94	14	270	2 x 6 x M12 x 28L
340	1,617	2,100	95	44	46.5	3.2000	340	142	106	180	272	150	120	18	346	2 x 6 x M12 x 32L
445	4,900	1,600	128	54	110.0	12.2000	445	190	139	236	344	202	160	25	459	2 x 6 x M16 x 45L
550	9,800	1,200	170	64	187.0	32.0000	550	230	173	290	430	246	170	26	513	2 x 6 x M18 x 56L
700	19,600	1,000	220	84	394.0	91.0000	700	310	220	370	544	326	220	26	660	2 x 6 x M24 x 70L

* Coupling Weight is without Bore Machining

KCS-P Type

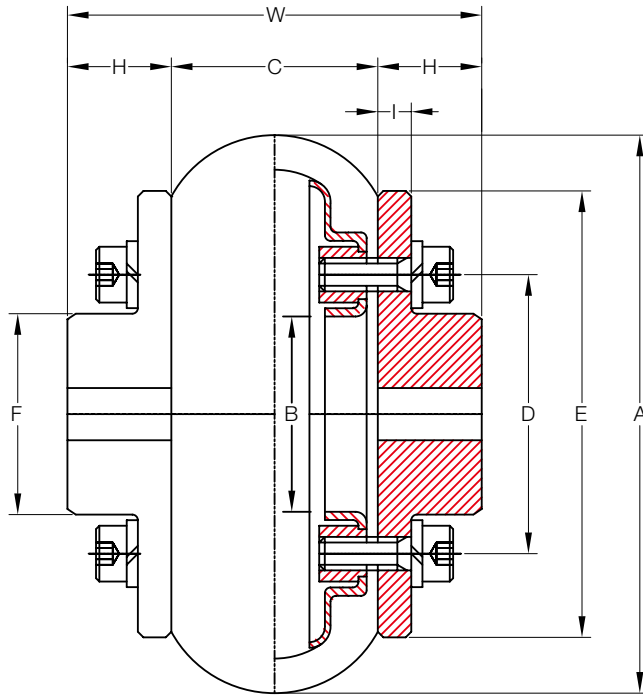

Size	Torque Rating (Nm)	Allow Speed RPM	Max Bore (mm)	Min Bore (mm)	Cplg Weight (Kg)	GD ² (Kg.cm-S ²)	Dimensions (Millimeters)									Hexa Bolt
							A	B	C	D	E	F	H	I	W	
100	50	5,000	22	8	1.0	0.0086	100	35	37	50	82	36	18	6	73	2 x 6 x M18 x 56L
120	98	4,500	28	10	1.9	0.0210	120	45	39	65	106	48	23	6	85	2 x 6 x M24 x 70L
140	147	4,200	35	14	2.8	0.0420	140	52	45	75	118	55	28	7	101	2 x 6 x M24 x 70L
160	216	4,000	42	18	4.3	0.0790	160	62	51	85	132	65	34	8	119	2 x 6 x M16 x 45L
185	294	3,600	48	24	6.5	0.1480	185	74	58	100	154	77	40	10	138	2 x 6 x M6 x 18L
220	490	3,200	55	30	10.4	0.3300	220	84	67	112	180	89	44	12	155	2 x 6 x M8 x 18L
265	980	2,600	75	40	18.8	0.9500	265	112	82	140	214	117	60	14	202	2 x 6 x M10 x 22L
340	1,617	2,100	95	44	41.5	3.4000	340	145	106	180	272	150	76	18	258	2 x 6 x M10 x 22L
445	4,900	1,600	128	54	87.4	11.6000	445	190	139	236	344	202	103	25	345	2 x 6 x M12 x 25L
550	9,800	1,200	170	64	165.0	30.0000	550	230	173	290	430	246	136	26	445	2 x 6 x M12 x 28L
700	19,600	1,000	220	84	355.0	84.0000	700	310	220	370	544	326	176	26	572	2 x 6 x M12 x 32L

* Coupling Weight is without Bore Machining

KCS-M Type

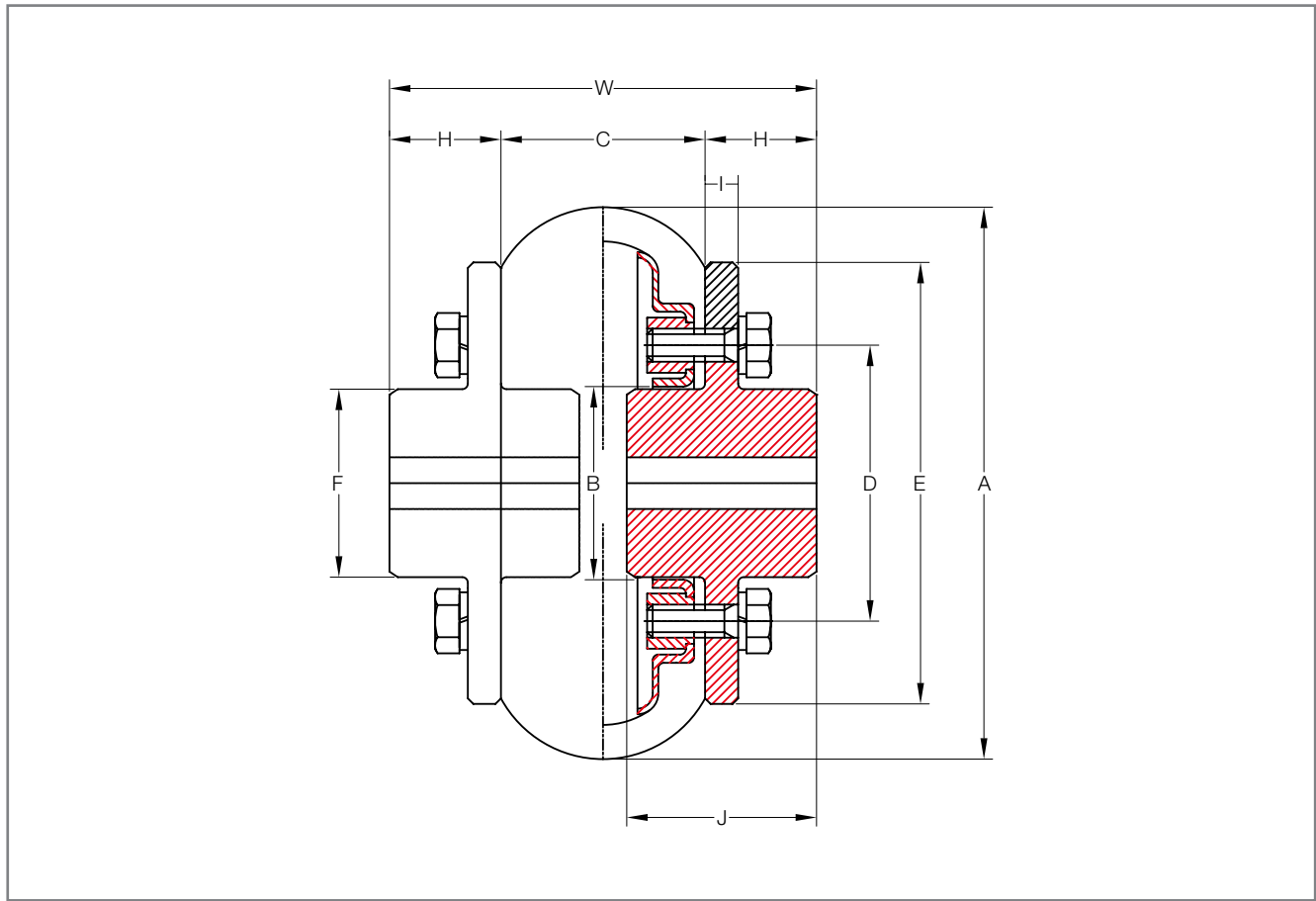

Size	Torque Rating (Nm)	Max Bore (mm)	Min Bore (mm)	Cplg Weight (Kg)	GD ² (Kg.cm-S ²)	Dimensions (Millimeters)											Hexa Bolt
						A	B	C	D	E	F	H	I	J	W		
100	50	20	8	1.0	0.0086	100	35	37	50	82	34	11	6	25	59	2 x 6 x M24 x 71L	
120	98	26	10	1.9	0.0210	120	45	39	65	106	44	18	6	32	75	2 x 6 x M18 x 50L	
140	147	30	14	2.8	0.0420	140	52	45	75	118	51	21	7	37	87	2 x 6 x M24 x 71L	
160	216	36	18	4.3	0.0790	160	62	51	85	132	61	27	8	45	105	2 x 6 x M6 x 18L	
185	294	44	24	6.5	0.1500	185	74	58	100	154	72	34	10	55	126	2 x 6 x M8 x 18L	
220	490	50	30	10.4	0.3200	220	84	67	112	180	82	36	12	60	139	2 x 6 x M10 x 20L	
265	980	66	40	18.8	0.9600	265	112	82	140	214	110	50	14	80	182	2 x 6 x M10 x 22L	
340	1,617	85	44	41.5	3.4000	340	142	106	180	272	140	61	18	100	228	2 x 6 x M12 x 25L	
445	4,900	115	54	87.4	11.4000	445	190	139	236	344	188	69	25	120	277	2 x 6 x M12 x 28L	
550	9,800	160	64	165.0	29.0000	550	230	173	290	430	228	97	26	160	367	2 x 6 x M12 x 28L	
700	19,600	210	84	355.0	83.0000	700	310	220	370	544	308	182	26	210	476	2 x 6 x M16 x 40L	

* Coupling Weight is without Disc and Bore Machining

KRB Type

KRF Type

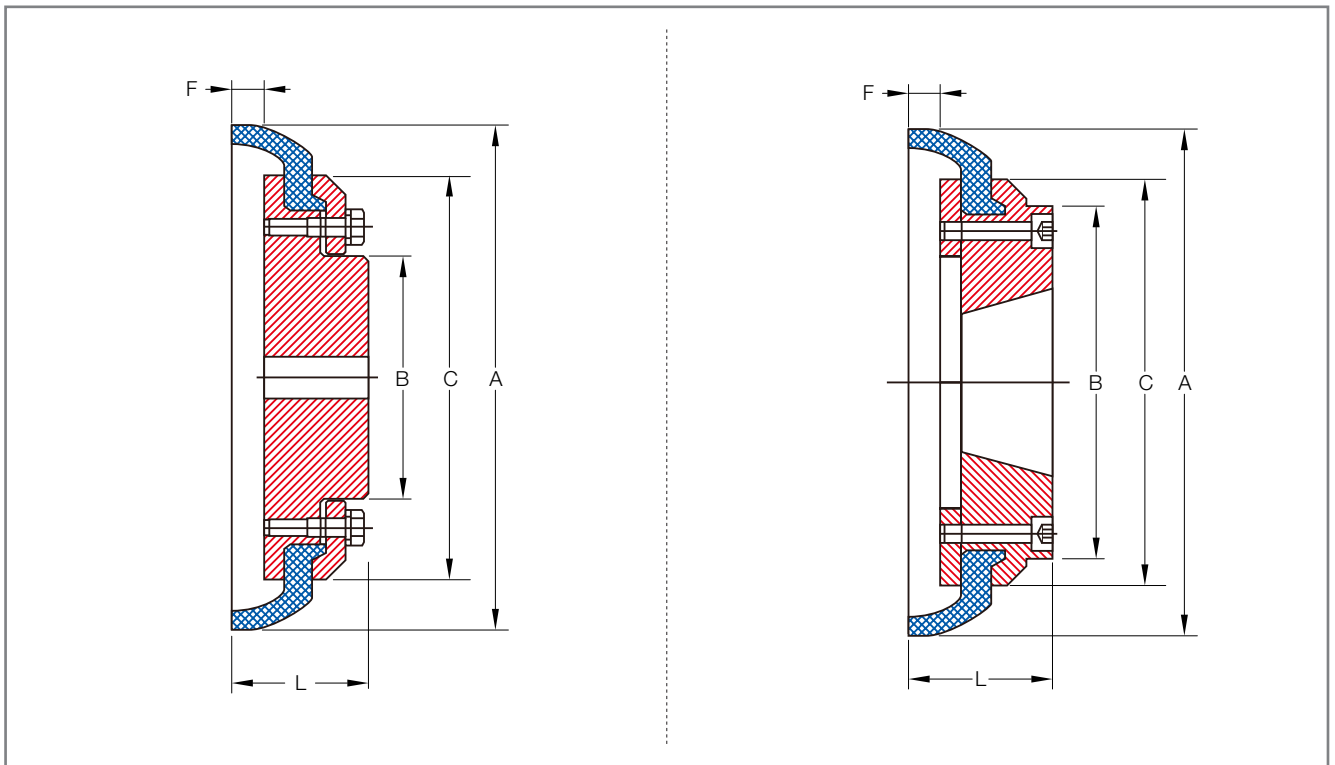

KRB Type

Size	Torque Rating (Nm)	Peak Torque Rating (Nm)	Allow Speed RPM	Max Bore (mm)	Cplg Weight (Kg)	Max. Parallel Misalignment (mm)	Max. End Float (mm)	Wrench Space (mm)	Dimensions (Millimeters)					Busing No.	Flange Fasteners		
									A	B	C	F	L		Size	Torque (Nm)	Per Flange
40	25	65	5,730	32	1.00	1.1	1.3	-	104	-	82	11	33.0	H7	M5	6	4
50	65	160	4,500	38	1.89	1.3	1.7	-	133	79	100	13	45.0	H7	M6	11	4
60	125	320	4,000	45	3.17	1.6	2.0	-	165	70	125	17	55.0	H7	M6	11	10
70	250	490	3,600	50	3.52	1.9	2.3	-	187	80	144	12	47.0	H7	M8	28	10
80	380	760	3,100	60	5.24	2.1	2.6	-	211	98	167	13	55.0	H7	M8	28	12
90	500	1,100	2,800	70	7.53	2.4	3.0	-	235	112	188	14	63.5	H7	M10	55	12
100	670	1,520	2,600	80	10.93	2.6	3.3	-	254	125	216	14	70.5	H7	M10	55	12
110	880	2,140	2,300	90	13.50	2.9	3.7	-	279	128	233	13	75.5	H7	M10	55	12
120	1,330	3,550	2,100	100	19.20	3.2	4.0	-	314	143	264	15	84.5	H7	M12	99	12
140	2,330	5,640	1,840	130	31.81	3.7	4.6	-	359	178	311	16	110.5	H7	M12	99	16
160	3,770	9,340	1,560	140	42.53	4.2	5.3	-	402	187	345	15	117.0	H7	M16	245	16
180	6,270	16,450	1,500	150	57.60	4.8	6.0	-	470	200	398	23	137.0	H7	M16	245	20
200	9,330	23,500	1,300	150	71.50	5.3	6.6	-	508	200	429	24	138.0	H7	M16	245	24
220	11,600	33,120	1,100	160	90.00	5.8	7.3	-	562	218	474	28	154.5	H7	M20	477	24
250	14,680	42,740	1,000	190	112.00	6.6	8.2	-	628	254	532	30	161.5	H7	M20	477	28

KRF Type

Size	Torque Rating (Nm)	Peak Torque Rating (Nm)	Allow Speed RPM	Max Bore (mm)	Cplg Weight (Kg)	Max. Parallel Misalignment (mm)	Max. End Float (mm)	Wrench Space (mm)	Dimensions (Millimeters)					Busing No.	Flange Fasteners		
									A	B	C	F	L		Size	Torque (Nm)	Per Flange
40	25	65	5,730	25	0.93	1.1	1.3	29	104	-	82	11	33.0	1008	M5	6	4
50	65	160	4,500	32	1.36	1.3	1.7	38	133	79	100	13	38.0	1210	M6	11	4
60	125	320	4,000	42	2.28	1.6	2.0	38	165	103	125	17	42.0	1610	M6	11	10
70	250	490	3,600	50	2.55	1.9	2.3	42	187	80	144	12	44.0	2012	M8	28	10
80	380	760	3,100	60	4.15	2.1	2.6	48	211	97	167	13	58.0	2517	M8	28	12
90	500	1,100	2,800	60	6.37	2.4	3.0	48	235	108	188	14	59.5	2517	M10	55	12
100	670	1,520	2,600	75	8.64	2.6	3.3	55	254	120	216	14	65.5	3020	M10	55	12
110	880	2,140	2,300	75	10.86	2.9	3.7	55	279	134	233	13	63.5	3020	M10	55	12
120	1,330	3,550	2,100	100	15.18	3.2	4.0	67	314	140	264	15	79.5	3525	M12	99	12
140	2,330	5,640	1,840	100	25.81	3.7	4.6	67	359	178	311	16	81.5	3525	M12	99	16
160	3,770	9,340	1,560	115	34.26	4.2	5.3	80	402	197	345	15	92.0	4030	M16	245	16
180	6,270	16,450	1,500	125	47.20	4.8	6.0	89	470	205	398	23	112.0	4535	M16	245	20
200	9,330	23,500	1,300	125	61.00	5.3	6.6	89	508	205	429	24	113.0	4535	M16	245	24
220	11,600	33,120	1,100	125	77.00	5.8	7.3	92	562	223	474	28	129.5	5040	M20	477	24

KW Flex Couplings

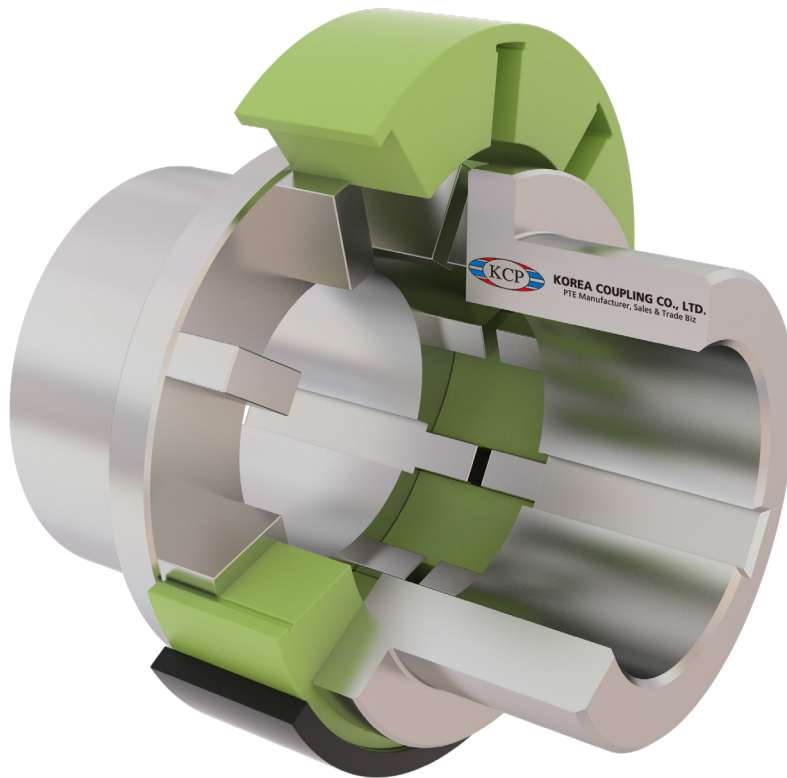

KCP KW Flex Coupling is designed to allow for quick and easy element replacement. Removal of hubs or the realignment of motors or drives is not required, which in turn reduces overall downtime.

Advanced production methods and innovative material selection allows for a higher capacity at a more competitive price.

KW Flex Coupling is non-lubricated and are designed from flexible urethane. The lack of need for lubrication decreases recurrent maintenance costs.

Available in both close-coupled and spacer designs, Urethane Flexible Couplings accommodate shaft diameters up to 186mm and torque loads up to 15,028 Nm

The urethane element has excellent resistance to wear and chemicals, and can be operated between temperatures of -40°C to 95°C .

The compact design of this coupling eliminates that need for coupling guard redesign for specific applications.

KW Flex Coupling Types

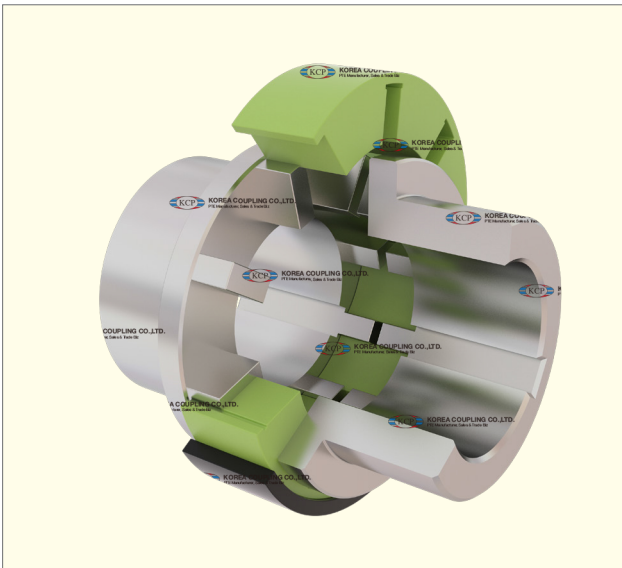

KW10 Type

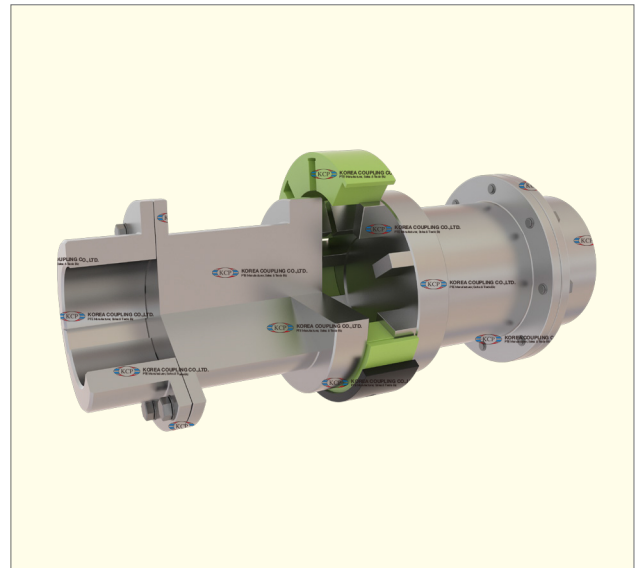

KW31 Type (Full Spacer)

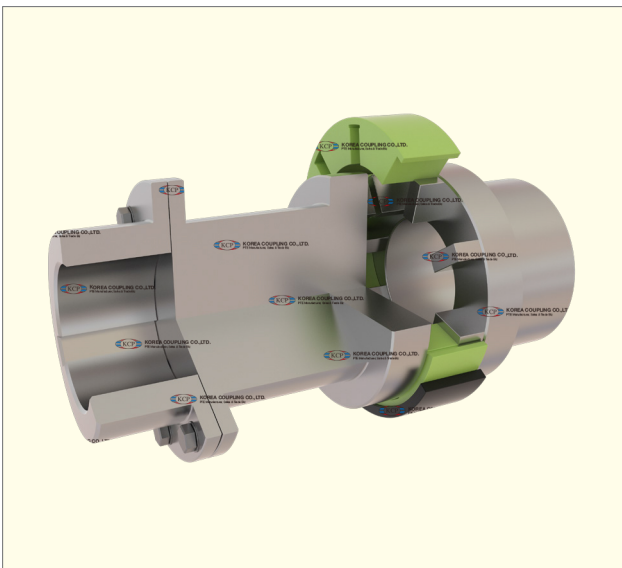

KW35 Type (Half Spacer)

KW10 Type

Close Coupled

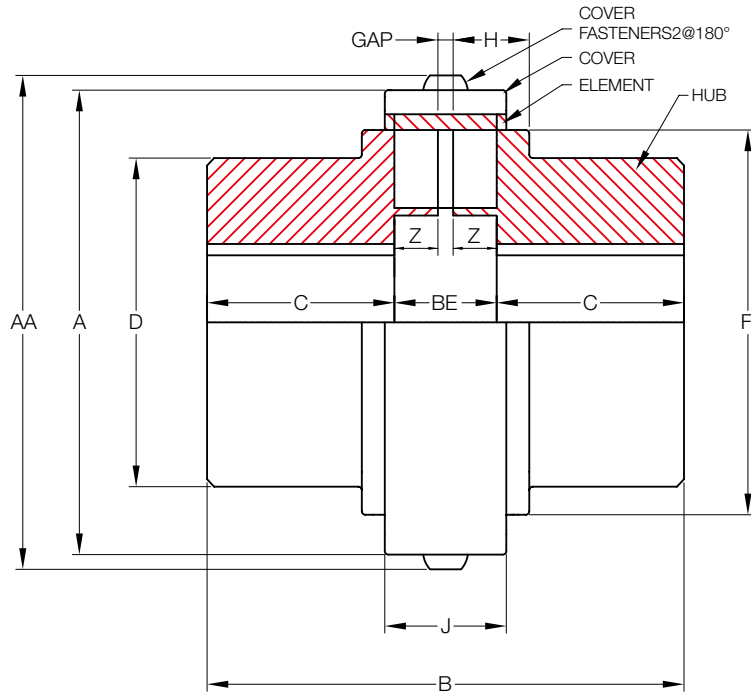

Size	Torque Rating (Nm)	Allow Speed RPM	Max Bore (mm)	Min Bore (mm)	Cplg Wt (Kg)		Dimensions (Millimeters)														Cover Fasteners	
					Nylon Cover	Steel Cover	A		AA		B	BE	C	D	F	H	J	Z	GAP	Size	Allen Wrench	
							Nylon	Steel	Nylon	Steel												
5	62	4,500	38	12.7	1.35	1.49	76.5	76.5	80.5	80.4	71.9	19.8	25.9	59.9	64	15.0	23.1	8.9	2	M4	M2.5	
10	130	4,500	48	15.88	2.49	2.72	90.4	90.4	94.5	94.4	91.9	23.9	34.0	72.1	75.9	19.1	27.9	10.9	2	M4	M2.5	
20	316	4,500	60	19.05	5.64	6.09	126.0	124.0	132.0	130.0	121.9	32.0	45.0	91.9	102.1	24.9	37.1	15.0	2	M6	M4	
30	520	4,500	65	25.40	9.41	10.00	146.6	143.0	153.0	149.0	151.9	36.1	57.9	104.9	118.1	29.0	41.9	17.0	2	M6	M4	
40	1,028	3,600	85	28.58	17.10	18.10	182.1	177.0	190.0	185.0	181.1	47.0	67.1	130.0	150.1	34.0	54.6	21.1	5	M8	M5	
50	2,508	3,000	105	31.75	35.80	37.70	230.9	224.0	239.0	232.0	214.9	60.7	77.0	178.1	190	46.0	69.6	27.9	5	M8	M5	
60	4,011	2,500	135	50.80	-	66.40	-	267.0	-	278.0	275.3	75.4	100.1	209.6	228.1	60.2	67.1	35.3	5	M10	M6	
70	8,011	2,100	160	69.85	-	111.00	-	310.0	-	321.0	324.1	84.1	119.9	251.0	270	69.6	74.9	39.6	5	M10	M6	
80	15,027	1,800	190	85.73	-	166.00	-	370.0	-	381.0	376.9	97.0	140.0	270.0	327.9	83.3	85.1	45.5	6	M10	M6	

* Coupling Weight is without Bore Machining

KW31 Type

Full Spacer

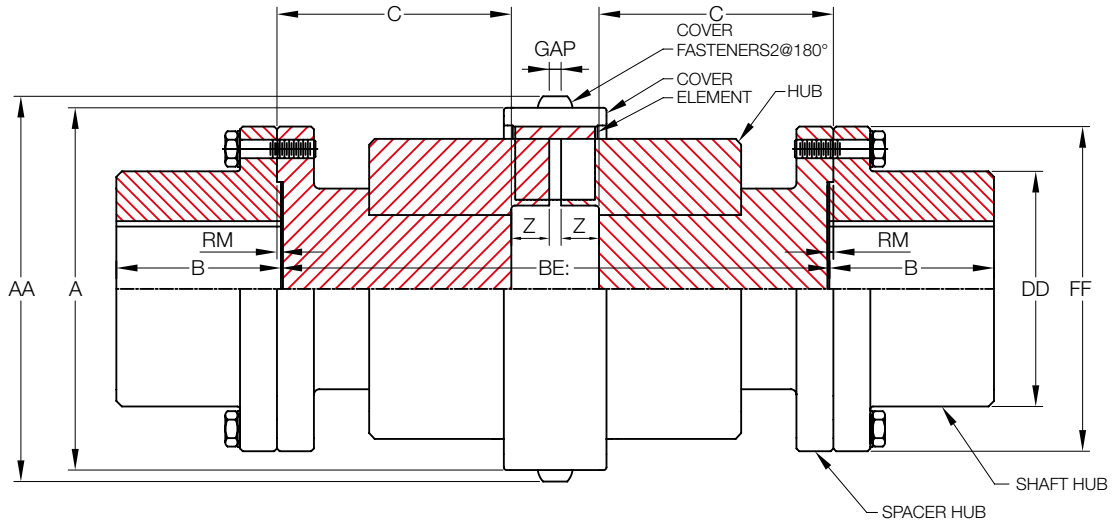

Size	Torque Rating (Nm)	Allow Speed RPM	Max Bore (mm)	Cplg Wt (Kg)		Dimensions (Millimeters)													Cover Fasteners		Flange Fasteners		T- Shaft Hub
				Min BE (Kg)	Add BE (Kg)	Distance Between Shaft Ends (BE) = 2(C) + 2(Z) + GAP - 2(RM)													Size	Allen Wrench	Size	Per Flange	
						Max	Min	Nylon	Steel	Nylon	Steel	B	BDD	FF	RM	S	Z	GAP					
5	62	4,500	35	3.63	0.014	235	80.9	76.5	76.5	80.5	80.4	34.9	52.4	86	1.27	27.4	8.9	2	M4	M2.5	M6	4	1020T
10	130	4,500	43	4.99	0.015	254	88.9	90.4	90.4	94.5	94.4	41.3	59.5	94	1.27	31.5	10.9	2	M4	M2.5	M6	8	1030T
20	316	4,500	56	9.53	0.027	254	88.9	126.0	124.0	132.0	130.0	54.0	78.6	113	1.27	27.4	15.0	2	M6	M4	M6	8	1040T
30	520	4,500	67	14.10	0.034	254	111.0	146.6	143.0	153.0	149.0	60.3	87.3	126	1.27	40.6	17.0	2	M6	M4	M8	8	1050T
40	1,028	3,600	85	25.90	0.040	311	127.0	182.1	177.0	190.0	185.0	79.4	109.5	153	1.27	46.7	21.1	5	M8	M5	M10	12	1070T
50	2,508	3,000	95	45.40	0.059	311	165.0	230.9	224.0	239.0	232.0	88.9	122.2	178	1.27	49.8	27.9	5	M8	M5	M12	12	1080T
60	4,011	2,500	110	72.60	0.082	311	200.0	-	267.0	-	278.0	101.6	142.9	210	1.27	-	35.3	5	M10	M6	M16	12	1090T
70	8,011	2,100	130	102.00	0.117	373	224.0	-	310.0	-	321.0	90.4	171.4	251	1.52	-	39.6	5	M10	M6	M20	12	1100T
70	8,011	2,100	150	120.00	0.117	373	224.0	-	310.0	-	321.0	104.1	196.8	276	1.52	-	39.6	5	M10	M6	M20	12	1110T
80	15,027	1,800	190	230.00	0.240	424	256.0	-	370.0	-	381.0	134.6	238.1	347	2.39	-	45.5	6	M10	M6	M27	12	1130T

* Coupling Weight is without Bore Machining

KW35 Type

Half Spacer

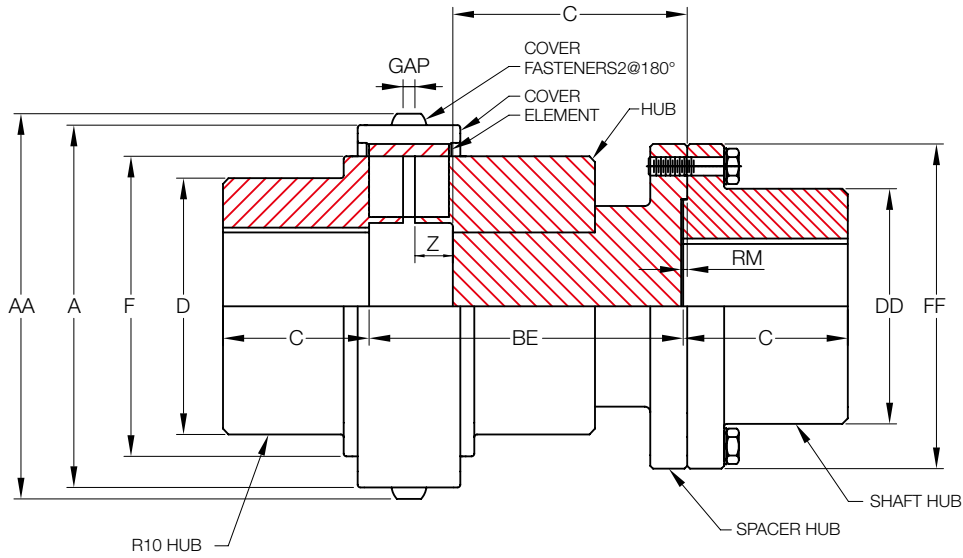

Size	Torque Rating (Nm)	Allow Speed RPM	Max Bore		Cplg Wt (Kg)		Dimensions (Millimeters)							
			T-Shaft Hub	KW10 Hub	Min BE (Kg)	Add BE (Kg)	Distance Between Shaft Ends (BE) = 2(C) + 2(Z) + GAP - 2(RM)							
							BE		A		AA		B	C KW10 Hub
5	62	4,500	35	38	2.54	0.014	127.0	50.5	76.5	76.5	80.5	80.4		
10	130	4,500	43	48	3.96	0.015	140.0	59.6	90.4	90.4	94.5	94.4	41.3	34.0
20	316	4,500	56	60	8.44	0.027	140.0	76.5	126.0	124.0	132.0	130.0	54.0	45.0
30	520	4,500	67	65	12.90	0.034	146.1	87.6	146.6	143.0	153.0	149.0	60.3	57.9
40	1,028	3,600	85	85	22.40	0.040	184.2	88.6	182.1	177.0	190.0	185.0	79.4	67.1
50	2,508	3,000	95	105	40.80	0.059	184.2	113.1	230.9	224.0	239.0	232.0	88.9	77.0
60	4,011	2,500	110	135	69.00	0.082	203.2	137.6	-	267.0	-	278.0	101.6	100.1
70	8,011	2,100	130	160	106.00	0.117	228.9	153.9	-	310.0	-	321.0	90.4	119.9
70	8,011	2,100	150	160	115.00	0.117	228.9	153.9	-	310.0	-	321.0	104.1	119.9
80	15,027	1,800	170	190	180.00	0.144	259.6	172.7	-	370.0	-	381.0	119.4	140.0
80	15,027	1,800	190	190	193.00	0.240	259.6	175.5	-	370.0	-	381.0	134.6	140.0

Size	Dimensions (Millimeters)									Cover Fasteners		Flange Fasteners		T- Shaft Hub
	Distance Between Shaft Ends (BE) = 2(C) + 2(Z) + GAP - 2(RM)									Size	Allen Wrench	Size	Per Flange	
	D	DD	F	FF	RM	S		Z	GAP					
5	159.9	52.4	64.0	86	1.27	27.4	15.9	8.9	2	M4	M2.5	M6	4	1020T
10	72.1	59.5	75.9	94	1.27	31.5	22.2	10.9	2	M4	M2.5	M6	8	1030T
20	91.9	78.6	102.1	113	1.27	27.4	25.4	15.0	2	M6	M4	M6	8	1040T
30	104.9	87.3	118.1	126	1.27	40.6	31.8	17.0	2	M6	M4	M8	8	1050T
40	130.0	109.5	150.1	153	1.27	46.7	41.3	21.1	5	M8	M5	M10	12	1070T
50	178.1	122.2	190.0	178	1.27	49.8	44.5	27.9	5	M8	M5	M12	12	1080T
60	209.6	142.9	228.1	210	1.27	-	-	35.3	5	M10	M6	M16	12	1090T
70	251.0	171.4	270.0	251	1.52	-	-	39.6	5	M10	M6	M20	12	1100T
70	251.0	196.8	270.0	276	1.52	-	-	39.6	5	M10	M6	M20	12	1110T
80	270.0	225.4	327.9	320	2.39	-	-	45.5	6	M10	M6	M24	12	1120T
80	270.0	238.1	327.9	347	2.39	-	-	45.5	6	M10	M6	M27	12	1130T

* Coupling Weight is without Bore Machining

Max Dynamic & Field Couplings



The unique halved flex element and reversible hubs reduce inventory and assembly time.

Max Dynamic Couplings are non-lubricated, material-flexing couplings constructed of a specially formulated polyurethane material designed for maximum durability, strength and fatigue resistance.

The polyurethane material bonded to metal eliminates assembly and slippage problems that often occur with mechanically clamped designs.

Due to their simple structure, Max Dynamic Couplings can be easily replaced or maintained without the separation of motors or connectors on the related line. Some misalignment of components in certain system is unavoidable. This coupling provides high misalignment capacity and low reactionary forces due to misalignment. The torsionally soft flex element cushions shock loads and vibration, which in turn extends equipment life.

Max Dynamic & Field Coupling Types

Max Dynamic Couplings



KD Type

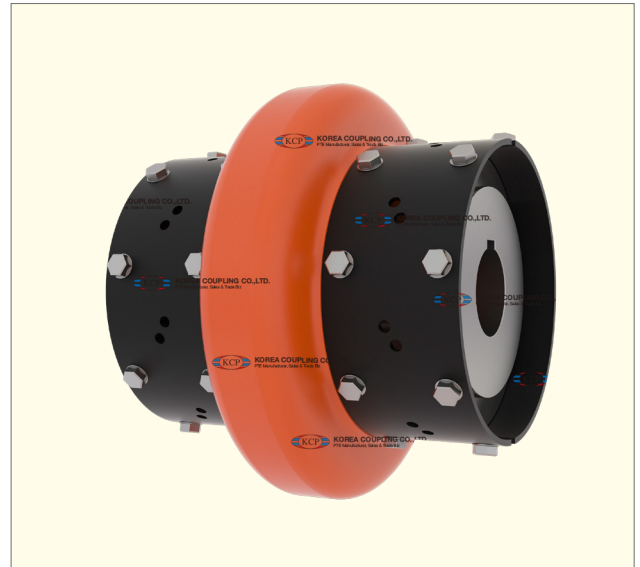

KDS Type (Spacer)

Max Field Couplings



KF Type



KFS Type (Spacer)

KD Type

Standard Type

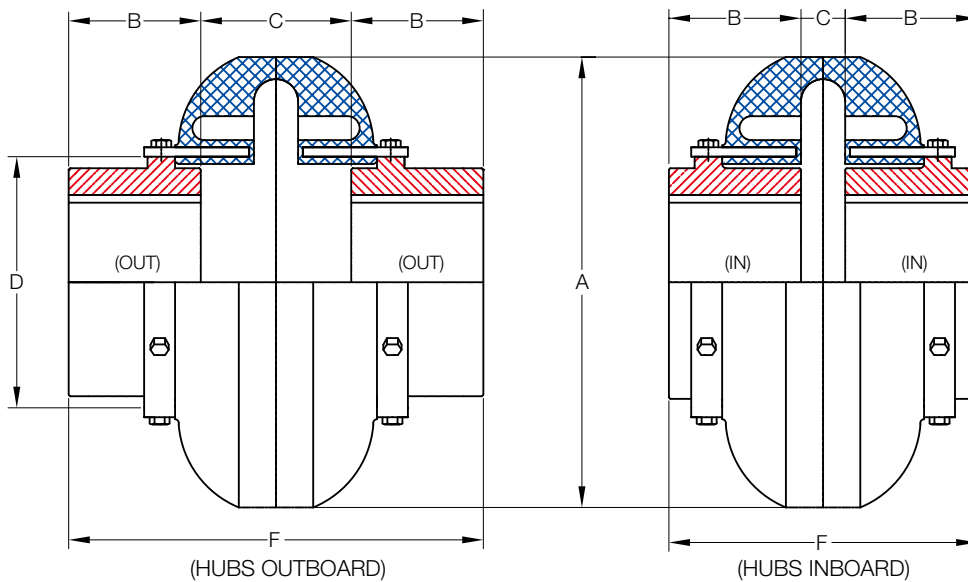

Size	Torque Rating (Nm)	Allow Speed RPM	Power Rating (kW)	Cplg Weight (Kg)	Max Bore (mm)	Min Bore (mm)	Dimensions (Millimeters)						
							A	B	C (Gap)		D	F	
									In	Out		In	Out
2	21.5	7,500	0.0023	0.55	28	13	89	24	35	47	47	83	95
3	41.2	7,500	0.0043	1.10	34	13	102	37	9	47	59	83	121
4	62.0	7,500	0.0066	1.40	42	13	116	37	9	47	66	83	121
5	108.0	7,500	0.0110	2.50	48	13	137	45	10	52	80	100	142
10	163.8	7,500	0.0170	3.70	55	13	162	45	11	53	93	101	143
20	260.0	6,600	0.0270	5.90	60	21	184	50	15	63	114	115	163
30	412.0	5,800	0.0430	9.60	75	21	210	56	12	68	138	124	180
40	622.0	5,000	0.0660	15.90	85	26	241	61	12	74	168	134	196
50	864.0	4,200	0.0900	24.50	90	26	279	69	12	86	207	150	224
60	1,412.0	3,800	0.1480	32.80	105	31	318	80	11	99	222	171	259
70	2,486.0	3,600	0.2620	39.00	120	31	356	85	18	109	235	189	281
80	4,463.0	2,000	0.4670	77.00	155	31	406	114	17	147	286	245	377
100	9,605.0	1,900	1.0000	111.00	171	48	533	140	44	95	359	324	375
120	19,221.0	1,800	2.0000	193.00	190	48	635	152	57	124	448	362	429

* Coupling Weight is without Bore Machining

KDS Type

Spacer Type

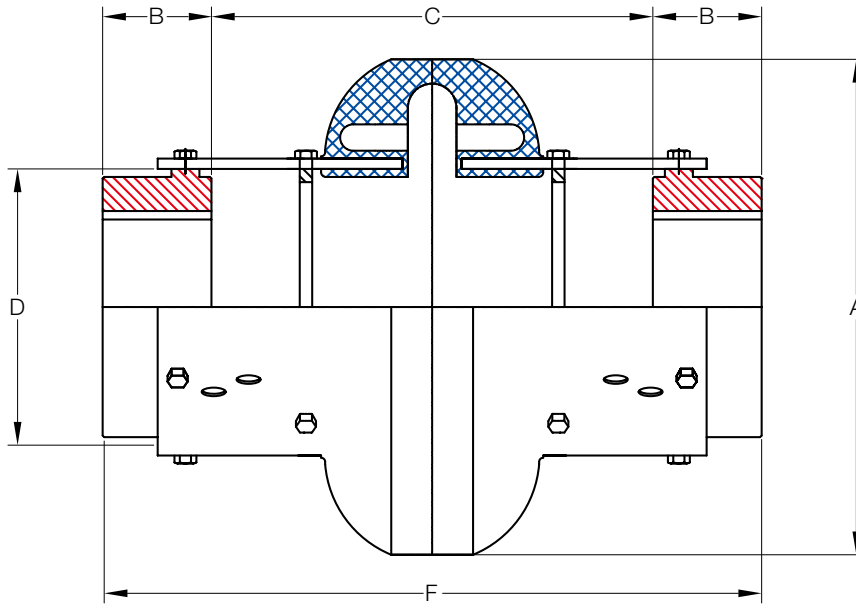

Size	Torque Rating (Nm)	Allow Speed RPM	Power Rating (kW)	Cplg Weight (Kg)	Max Bore (mm)	Min Bore (mm)	Dimensions (Millimeters)						
							A	B	C (Gap)		D	F	
									In	Out		In	Out
2	21.5	7,500	0.0023	1.0	28	13	89	24	91	100	47	146	149
3	41.2	7,500	0.0043	1.8	34	13	102	37	85	140	59	184	216
4	62.0	7,500	0.0066	2.3	42	13	116	37	85	140	66	184	216
5	104.5	7,500	0.0110	3.4	48	13	137	45	89	140	80	184	228
10	163.8	7,500	0.0170	4.7	55	13	162	45	89	140	93	184	228
20	260.0	4,800	0.0270	7.1	60	21	184	50	67	180	114	238	280
30	412.0	4,200	0.0430	11.4	75	21	210	56	54	180	138	238	293
40	622.0	3,600	0.0660	18.2	85	26	241	61	41	180	168	238	307
50	864.0	3,100	0.0900	27.3	90	26	279	69	28	180	207	238	319
60	1,412.0	2,800	0.1480	38.2	105	31	318	80	66	250	222	318	415
70	2,486.0	2,600	0.2620	46.4	120	31	356	85	59	250	235	318	421
80	4,463.0	1,800	0.4670	81.8	155	31	406	114	37	250	286	318	478

* Coupling Weight is without Bore Machining

KF Type

Standard Type

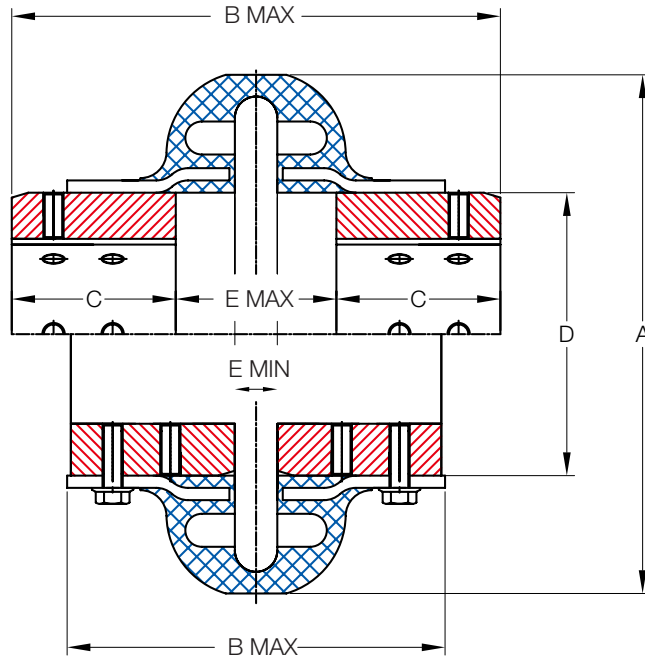

Size	Torque Rating (Nm)	Allow Speed RPM	Cplg Weight (Kg)	Max Bore (mm)	Min Bore (mm)	Dimensions (Millimeters)						
						A	B		C	D	E	
							Max	Min			Max	Min
110	64	5,400	0.474	38	10	110	128	96	38	60	52	8
125	106	5,400	0.550	48	10	120	130	97	38	70	52	8
130	170	5,100	0.700	55	11	131	131	95	41	80	49	7
150	256	4,800	1.020	65	11	150	159	111	51	95	57	9
170	312	4,800	1.196	65	11	168	159	111	51	95	57	9
190	420	4,600	1.526	75	19	190	161	113	52	117	57	7
215	670	4,300	2.506	80	19	216	192	132	64	140	64	11
245	970	4,100	3.080	95	19	245	203	136	65	171	73	8
290	1,450	3,900	4.500	110	27	290	240	154	73	215	94	8
365	3,300	3,600	11.800	127	35	365	311	200	90	235	131	20
425	5,700	2,000	14.800	155	35	425	361	247	114	286	133	19
460	6,400	2,000	17.200	165	48	460	380	267	124	302	132	19

* Coupling Weight is without Bore Machining

KFS Type

Spacer Type

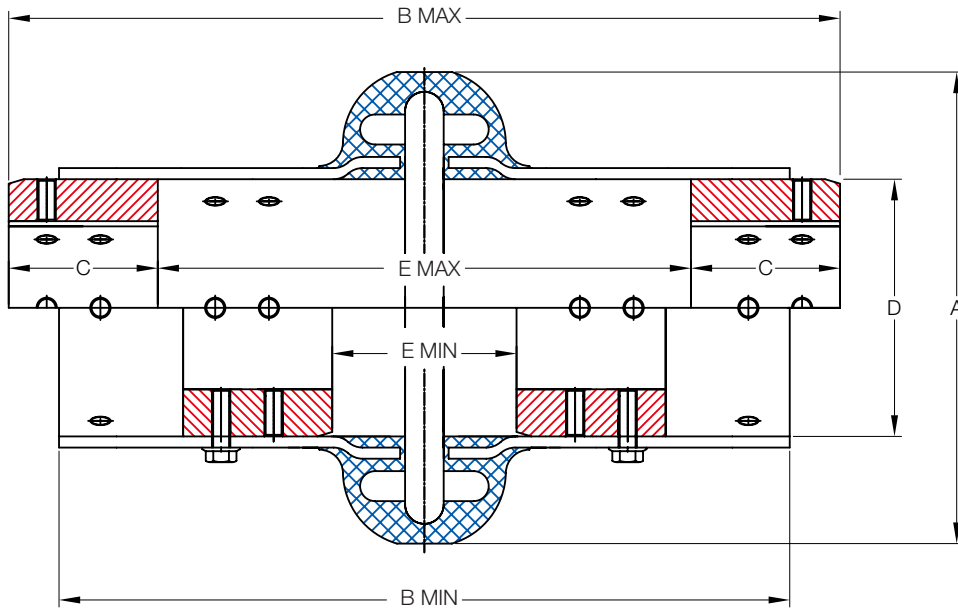

Size	Torque Rating (Nm)	Allow Speed RPM	Cplg Weight (Kg)	Max Bore (mm)	Min Bore (mm)	Dimensions (Millimeters)						
						A	B		C	D	E	
							Max	Min			Max	Min
110	64	4,300	0.764	38	10	110	213	180	38	60	137	41
125	106	4,300	0.920	48	10	120	220	187	38	70	144	52
130	170	4,200	1.130	55	11	131	214	179	41	80	132	49
150	256	4,000	1.760	65	11	150	276	232	51	95	174	57
170	312	4,000	1.940	65	11	168	276	232	51	95	174	57
190	420	3,900	2.500	75	19	190	278	232	52	117	174	57
215	670	3,800	4.100	80	19	216	309	248	64	140	181	57
245	970	3,700	5.180	95	19	245	323	256	65	171	193	66
290	1,450	3,600	8.540	110	27	290	401	312	73	215	255	72
365	3,300	2,600	15.440	127	35	365	428	318	90	235	250	76
425	5,700	1,800	19.320	155	35	425	478	318	114	286	250	68
460	6,400	1,800	22.080	165	48	460	498	318	124	302	250	67

* Coupling Weight is without Bore Machining

Nylon Coupling

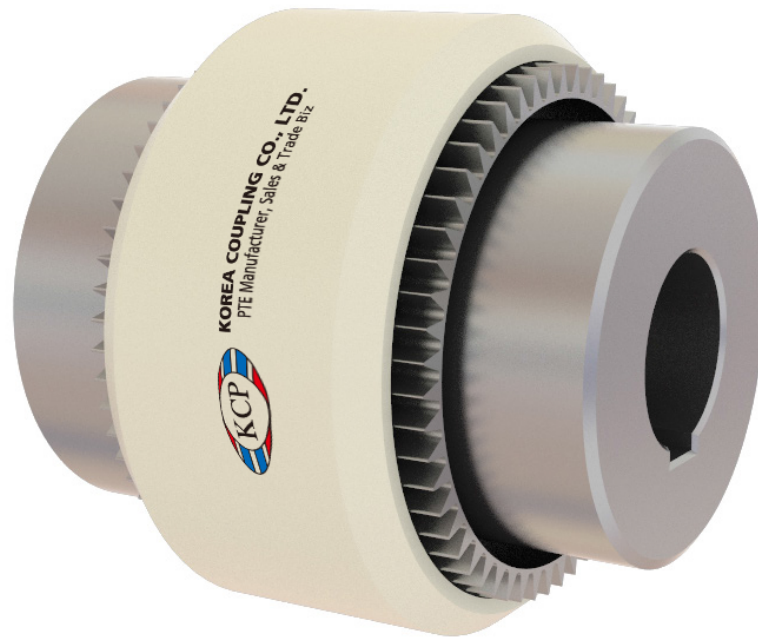

KCP Nylon Coupling is torsionally rigid power transmission couplings. Their flexible shaft connections transmit torque between two steel gear hubs and the internal teeth of a nylon drive sleeve. These couplings are specifically suitable to compensate for shaft misalignment, whether axial, radial, and/or angular.

Single or double engagement options make the Nylon Couplings suitable for a variety of applications. The spacer type connections can accommodate large shaft end gaps. Nylon couplings can be assembled both vertically and horizontally. There is no need for any special assembly tools. Nylon Couplings are non-lubricated and low noise.

The steel hubs and nylon sleeves are a material combination that allows for maintenance-free, continuous operation and very low friction on the teeth. In the case of misalignment in couplings between hubs with spur teeth, high edge pressure can develop on the contact surfaces. This can lead to considerable wear.

The curved teeth of the Nylon Couplings avoid edge pressure on the coupling, even in the case of angular and radial misalignment.

KM Type

Close Coupled

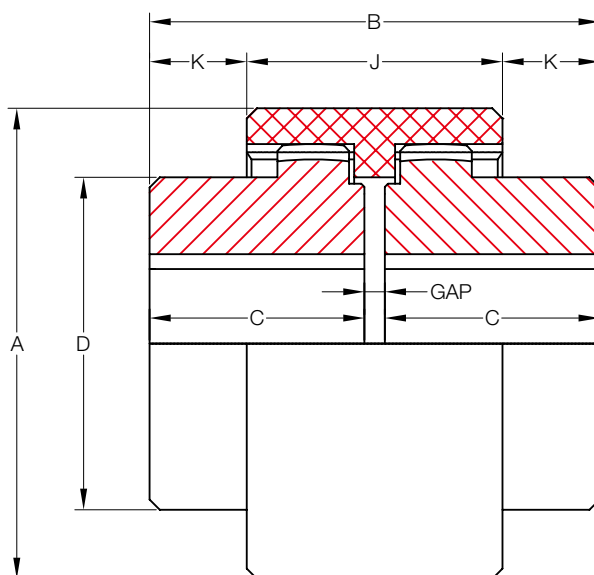

Size	Torque Rating (Nm)	Allow Speed RPM	Max Bore (mm)	Min Bore (mm)	Dimensions (Millimeters)						
					A	B	C	D	J	K	GAP
14	17	14,000	14	6	40	50	23	25	37	6.5	4
19	30	11,800	19	8	48	54	25	32	37	8.5	4
24	37	10,600	24	10	52	56	26	36	41	7.5	4
28	69	8,500	28	10	66	84	40	45	46	19.0	4
32	90	7,500	32	12	76	84	40	50	48	18.0	4
38	127	6,700	38	14	83	84	40	58	48	18.0	4
42	164	6,000	42	20	92	88	42	65	50	19.0	4
48	202	5,600	48	20	100	104	50	68	50	27.0	4
65	436	4,000	65	25	140	144	70	96	72	36.0	4
80	692	3,150	80	30	175	186	90	124	93	46.5	6
100	1,246	3,000	100	40	210	228	110	152	102	63.0	8
125	2,749	2,120	125	50	270	290	140	192	134	78.0	10

* Coupling Weight is without Bore Machining

Wire Drum Coupling



KCP Wire Drum Coupling is designed for installation in the drum drive of crane or conveying systems. This coupling can be used in the difficult and rough operating conditions associated with iron and steel work, or in the continuous heavy load operations of shore cranes.

Wire Drum Coupling absorbs pressure stress caused by the high torque and high radial loads resulting from the larger surface areas of these applications.

The design of this coupling prevents the danger of roller and bore breakage due to bending stress. The circular teeth on this coupling produces dramatically lower stress as compared to the bending stress involved with typical gear teeth.

The torque moment in the coupling is transmitted in two ways. First, through the two drag faces of the sleeve which is housed in the drum. Secondly, through a series of bolts which are fixed to the drum.

Wire Drum Coupling can compensate for angular misalignments of up to 1° , via a crown which allows the hub to oscillate with respect to the sleeve.

Depending on the size of the selected coupling, axial displacements from $\pm 3\text{mm}$ up to $\pm 8\text{mm}$ can be absorbed. Such couplings are not suitable for absorption or transmission of axial forces.

The following figure shows an example assembly of a Wire Drum Coupling in a hoisting gear. The coupling's hub is placed at the end of the wire drum. The bearing bracket must be configured as a fixed bracket.

KWC Type

Crown Roller

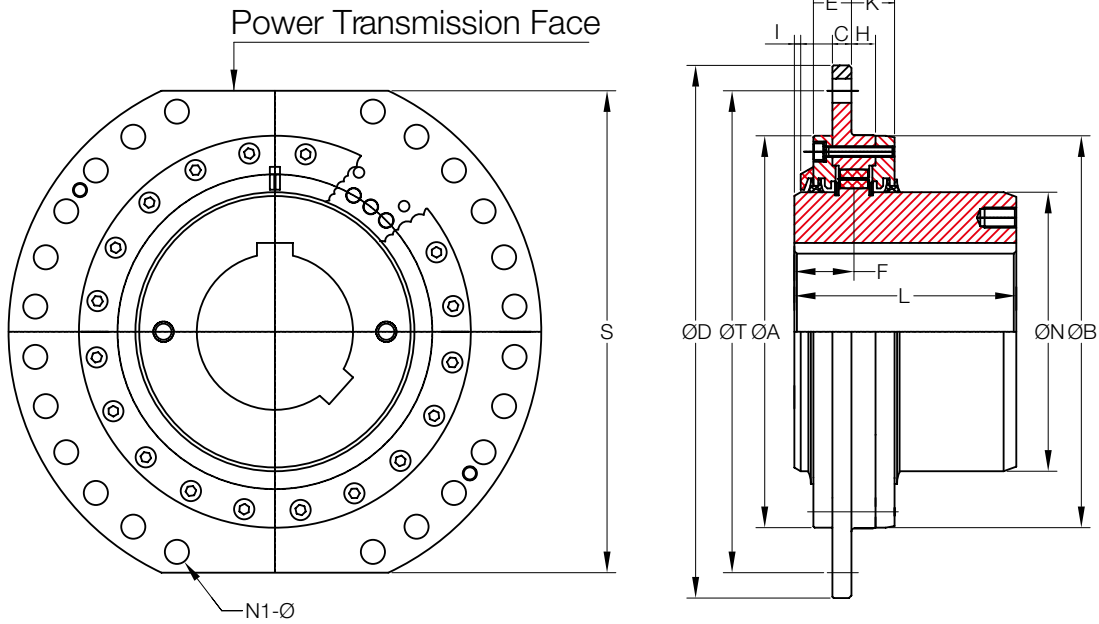

Size	Torque Rating (Nm)	Radial Load (Kg)	Cplg Weight (Kg)	Max Bore mm	Min Bore (mm)	GD (Kg. m ²)	Dimensions (Millimeters)																Drum		Max Clearance
							D	T	A	B	N	I	C	H	E	K	L	S	F	Fixing Holes					
							N1	ø																	
25	4,510	1,450	12	65	40	0.24	250	220	159	160	95	5	12	16	42	31	95	220	44	6	15	3			
50	5,980	1,680	19	75	50	0.40	280	250	179	180	110	5	12	16	42	31	100	240	44	6	15	3			
75	7,500	1,885	23	85	60	0.70	320	280	199	200	125	5	15	17	45	32	110	280	46	6	19	4			
100	9,015	2,040	27	95	60	1.00	340	300	219	220	140	5	15	17	45	32	125	300	46	6	19	4			
130	15,485	3,160	38	105	80	1.30	360	320	239	240	160	5	15	19	45	34	130	320	47	6	19	4			
160	19,500	3,570	48	120	80	1.80	380	340	259	260	180	5	15	19	45	34	145	340	47	6	19	4			
200	24,010	3,930	62	135	100	2.40	400	360	279	280	200	5	15	19	45	34	170	360	47	6	19	4			
300	27,980	4,285	76	145	100	3.30	420	380	309	310	220	5	15	19	45	34	175	380	47	6	19	4			
400	37,975	5,000	105	175	100	6.00	450	400	339	340	260	9	20	22	60	40	185	400	61	6	24	4			
600	69,970	11,735	190	205	120	15.00	550	500	419	420	310	7	20	22	60	42	240	500	61	6	24	6			
1000	120,000	12,755	240	230	140	21.00	580	530	449	450	350	7	20	22	60	42	260	530	61	8	24	6			
1500	180,000	15,305	400	280	160	47.00	650	600	529	530	415	7	25	27	65	47	315	580	66	8	24	6			
2600	310,000	25,510	500	300	170	64.00	680	630	559	560	445	7	25	34	65	54	350	600	69	24	24	8			
3400	400,000	31,295	630	315	200	94.00	710	660	599	600	475	16	35	34	81	56	380	640	83	24	28	8			
4200	500,000	34,695	840	355	230	154.00	780	730	669	670	535	16	35	34	81	56	410	700	83	24	28	8			
6200	685,000	38,775	1,120	400	260	248.00	850	800	729	730	600	13	35	34	81	59	450	760	83	24	28	8			

* Coupling Weight is without Bore Machining

Flange Flexible Couplings

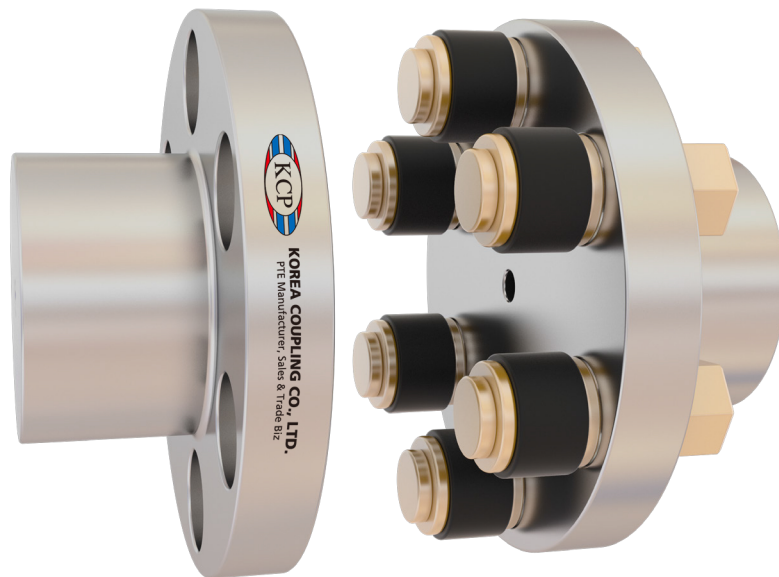

KCP Flange Flexible Couplings are used to connect shaft lines.

Flange Couplings transmit power smoothly, and these couplings can absorb shock load and vibration.

Flange Couplings do not require lubrication and are virtually maintenance free. The simplified form of this piece enables a quick and easy installation. These couplings are easy and low cost to assemble and disassemble.

The Flange Flexible Couplings can safely operate without any hard covers.

Flange Flexible Coupling Types

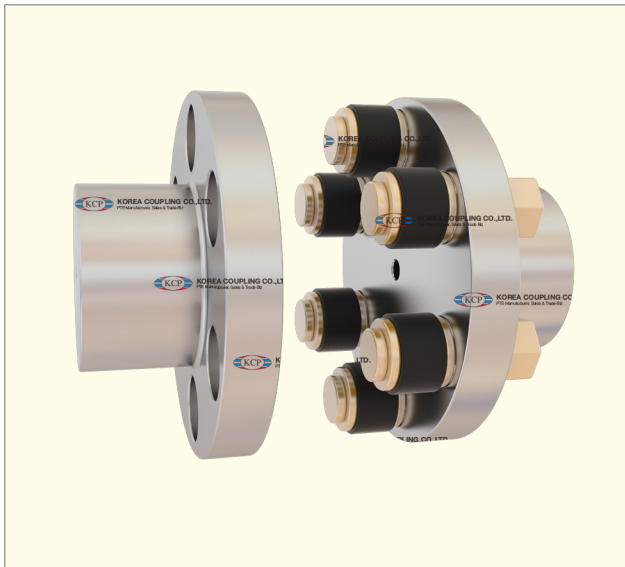

KFF Type

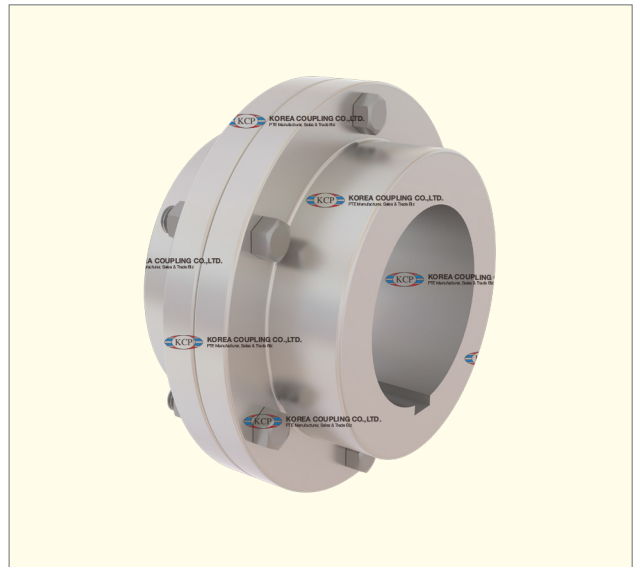

KFR Type



KFS Type (Spacer)

KFF Type

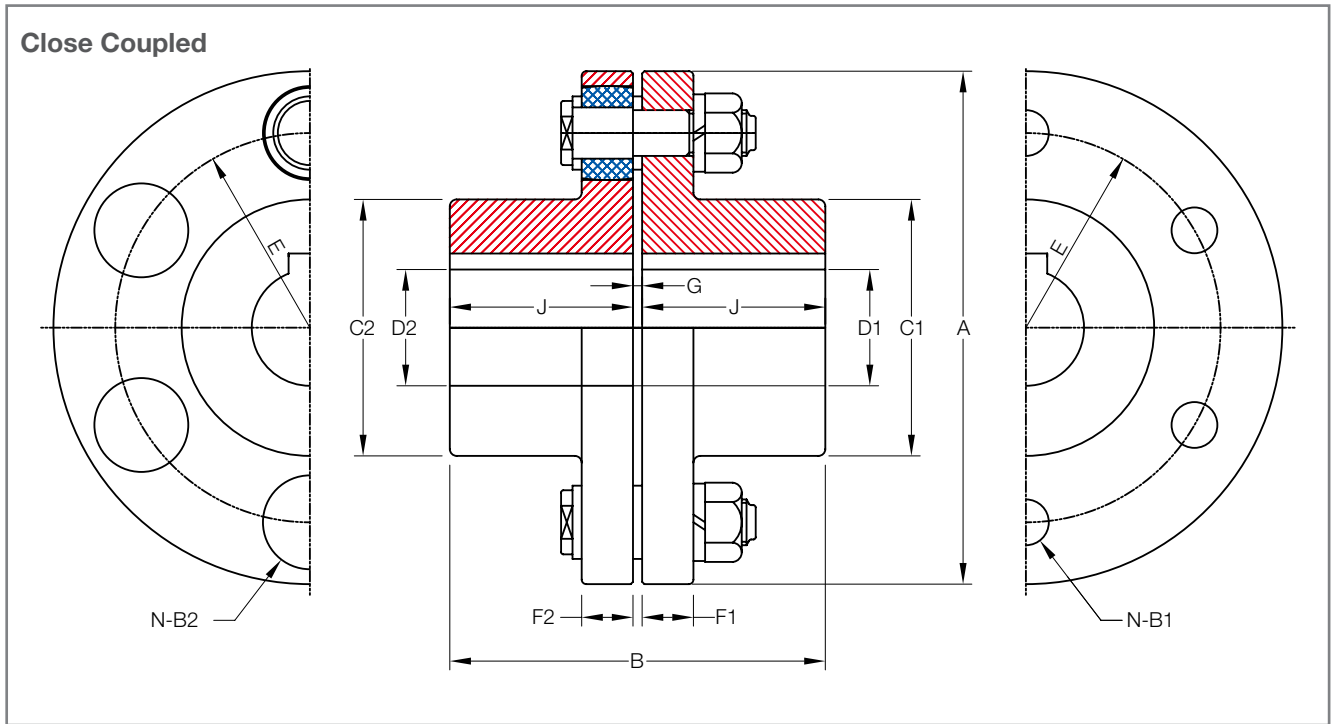

Size	Torque Rating (Nm)	Allow Speed RPM	Bore Dia			Cplg Weight (Kg)	GD (Kg.m ²)	Dimensions (Millimeters)								Bolt Hole			
			Max Bore		Min			A	B	C1	C2	F1	F2	J	G	E	N	B1	B2
			D1	D2															
90	5	4,000	20	20	-	1.37	0.00532	90	59	35.5	35.5	14	14.0	28.0	3	60	4-KB6-01	8.0	19
100	10	4,000	25	25	-	2.00	0.00948	100	74	42.5	42.5	16	16.0	35.5	3	67	4-KB6-02	10.0	23
112	16	4,000	28	28	16	2.64	0.01520	112	83	50.0	50.0	16.0	16.0	40.0	3	75	4-KB6-02	10.0	23
125	25	4,000	32	28	18	3.59	0.02580	125	93	56.0	50.0	18.0	18.0	45.0	3	85	4-KB6-03	14.0	32
140	50	4,000	38	35	20	4.88	0.04220	140	103	71.0	63.0	18.0	18.0	50.0	3	100	6-KB6-03	14.0	32
160	110	4,000	45	45	25	6.70	0.07410	160	115	80.0	80.0	18.0	18.0	56.0	3	115	8-KB6-03	14.0	32
180	157	3,500	50	50	28	8.98	0.12100	180	129	90.0	90.0	18.0	18.0	63.0	3	132	8-KB6-03	14.0	32
200	245	3,200	56	56	32	13.90	0.24100	200	146	100.0	100.0	22.4	22.4	71.0	4	145	8-KB6-04	20.0	41
224	392	2,850	63	63	35	18.10	0.38400	224	164	112.0	112.0	22.4	22.4	80.0	4	170	8-KB6-04	20.0	41
250	617	2,550	71	71	40	26.60	0.72000	250	184	125.0	125.0	28.0	28.0	90.0	4	180	8-KB6-05	25.0	51
280	980	2,300	80	80	50	37.40	1.29000	280	204	140.0	140.0	40.0	28.0	100.0	4	200	8-KB6-06	28.0	57
315	1,570	2,050	90	90	63	50.30	2.12000	315	228	160.0	160.0	40.0	28.0	112.0	4	236	10-KB6-06	28.0	57
355	2,450	1,800	100	100	71	79.20	4.42000	355	255	180.0	180.0	56.0	35.5	125.0	5	260	8-KB6-07	35.5	72
400	3,920	1,600	110	110	80	100.00	7.10000	400	255	200.0	200.0	56.0	35.5	125.0	5	300	10-KB6-07	35.5	72
450	6,175	1,400	125	125	90	132.00	11.50000	450	285	224.0	224.0	56.0	35.5	140.0	5	355	12-KB6-07	35.5	72
560	9,800	1,150	140	140	100	207.00	27.30000	560	325	250.0	250.0	56.0	35.5	160.0	5	450	14-KB6-07	35.5	72
630	15,680	1,000	160	160	110	271.00	44.10000	630	365	280.0	280.0	56.0	35.5	180.0	5	530	18-KB6-07	35.5	72

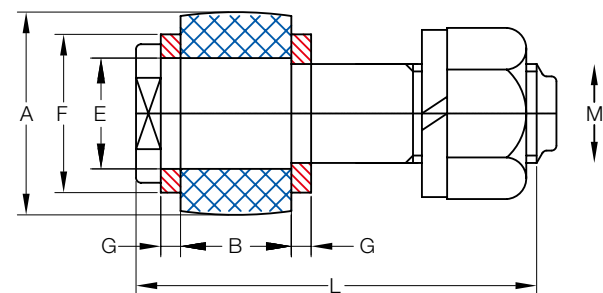

* Coupling Weight is without Bore Machining

Size	Dimensions (Millimeters)						
	A	F	E	M	B	G	L
KB6-01	18	14	9.0	8	14.0	3	50
KB6-02	22	18	12.0	10	16.0	3	56
KB6-03	31	25	16.0	12	18.0	3	64
KB6-04	40	32	22.4	20	22.4	4	85
KB6-05	50	40	28.0	24	28.0	4	100
KB6-06	56	45	31.5	24	40.0	4	116
KB6-07	71	56	40.0	30	56.0	5	150

KFR Type

Close Coupled

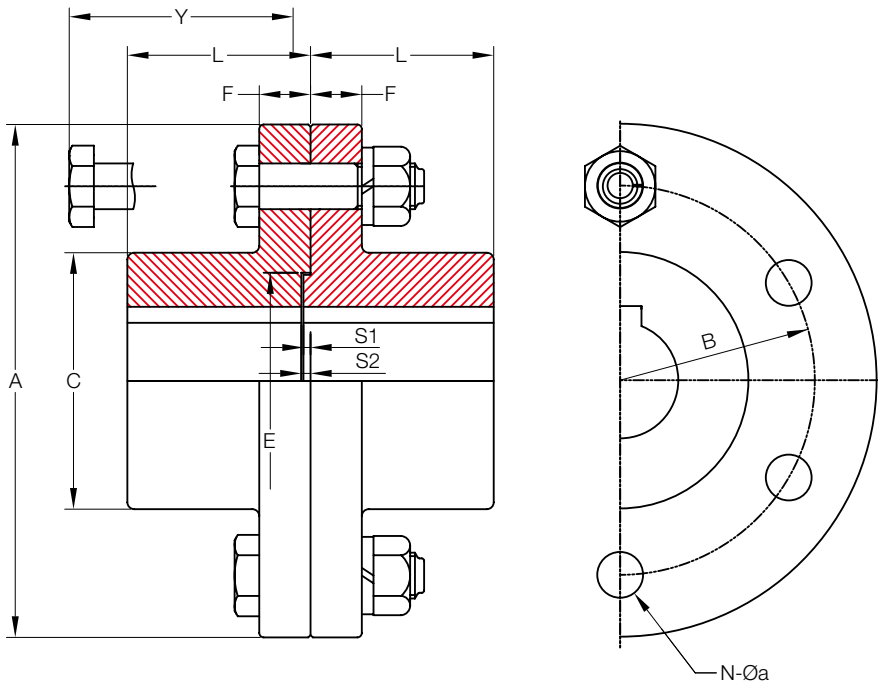

Size	Torque Rating (Nm)	Allow Speed RPM	Max Bore (mm)	Min Bore (mm)	Cplg Weight (Kg)	GD (Kg.m ²)	Dimensions (Millimeters)							Spigot and Socket		
							A	L	C	B	F1	Y	N-Øa	E	S1	S2
112	62	4,000	28	16	2.78	0.0163	112	40	50	75	16	70	4-Ø10	40	3	2
125	88	4,000	28	18	3.76	0.0276	125	45	56	85	18	81	4-Ø14	45	3	2
140	176	4,000	35	20	5.06	0.0449	140	50	71	100	18	81	6-Ø14	56	3	2
160	348	4,000	45	25	6.98	0.0788	160	56	80	115	18	81	8-Ø14	71	3	2
180	490	3,500	50	28	9.23	0.1290	180	63	90	132	18	81	8-Ø14	80	3	2
200	696	3,200	56	32	14.40	0.2550	200	71	100	145	22.4	103	8-Ø16	100	4	3
224	980	2,850	63	35	18.40	0.4050	224	80	112	170	22.4	103	8-Ø16	100	4	3
250	1,372	2,550	71	40	27.80	0.7630	250	90	125	180	28	126	8-Ø20	112	4	3
280	1,960	2,300	80	50	38.90	1.3700	280	100	140	200	28	126	8-Ø20	125	4	3
315	2,744	2,050	90	63	51.20	2.2300	315	112	160	236	28	126	8-Ø25	140	4	3
355	2,920	1,800	100	71	81.40	4.6700	355	125	180	260	35.5	157	10-Ø20	160	4	4

* Coupling Weight is without Bore Machining

KFS Type

Spacer Type

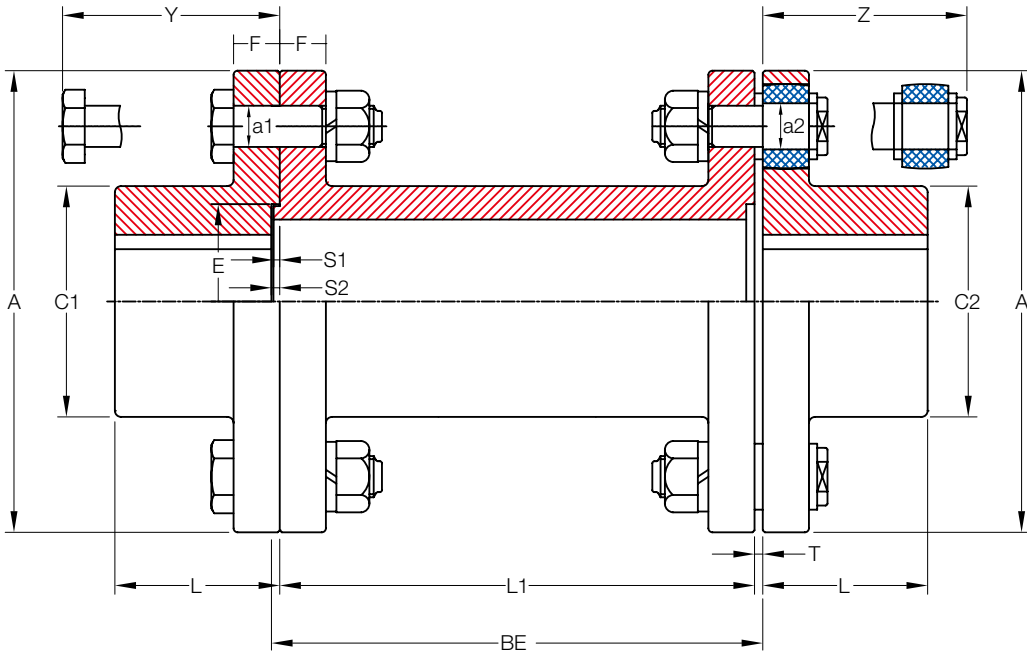

Size	Torque Rating (Nm)	Allow Speed RPM	Bore Dia			Dimensions (Millimeters)									Bolt			
			Max Bore		Min	BE			L1			T	Rigid		Flexible			
			D1	D2									N	$\alpha 1 \times L$	N	$\alpha 1 \times L$		
125	25	4,000	32	29	18	100	-	-	-	97	-	-	-	3	4	4- $\phi 14 \times 53$	4	$\phi 14 \times 64$
140	50	4,000	38	35	20	100	140	-	-	97	137	-	-	3	6	4- $\phi 14 \times 53$	6	$\phi 14 \times 64$
160	110	4,000	45	45	25	100	140	-	-	97	137	-	-	3	8	6- $\phi 14 \times 53$	8	$\phi 14 \times 64$
180	157	3,500	50	50	28	100	140	180	-	97	137	177	-	3	8	8- $\phi 14 \times 53$	8	$\phi 14 \times 64$
200	245	3,200	56	56	32	140	180	220	-	136	176	216	-	4	8	8- $\phi 14 \times 67$	8	$\phi 20 \times 85$
224	392	2,850	63	63	35	140	180	220	-	136	176	216	-	4	8	8- $\phi 16 \times 67$	8	$\phi 20 \times 85$
250	617	2,550	71	71	40	140	180	220	260	136	176	216	256	4	8	8- $\phi 20 \times 82$	8	$\phi 25 \times 100$
280	980	2,300	80	80	50	180	220	260	300	176	216	256	296	4	8	8- $\phi 20 \times 82$	8	$\phi 28 \times 116$
315	1,568	2,050	90	90	63	180	220	260	300	176	216	256	296	4	10	8- $\phi 20 \times 82$	10	$\phi 28 \times 116$

* Coupling Weight is without Bore Machining

Universal Joints



KCP Universal Joints are considered to be one of the oldest flexible couplings.

The Universal Joints, in their simplest form, consist of two shaft yokes at right angles to each other and a four point cross which connects the yokes. The cross sits inside the bearing cap assemblies, which are pressed into the eyes of the yokes.

The modern Universal Joints have become much more complex than their simple ancestor described above. In general, industrial applications must operate continuously with high torque loads. Industrial applications demand maximum strength and life of all components, including Universal Joints.

Universal Joints have several unique features that make it ideal for a variety of application. The most significant of these features is the ability of the Universal Joints to operate at high misalignment angles.

Another key feature of Universal Joints is the design of the bearing and seal, which resists lubrication loss and contamination. This makes Universal Joints suitable for applications where harsh atmospheric conditions would prohibit the use of other couplings.

The Universal Joints can be used either as a single joint or in pairs. However, use of the Universal Joints as a single joint, only accommodates angular misalignment.

Since nearly every application requires the coupling to accommodate offset misalignment as well as angular, the Universal Joints should be used in pairs. Using the Universal Joint in pairs also corrects for any non-uniform angular velocity that can be caused by a single joint.

Universal Joint Types



KL Type



KLD Type



KLS Type

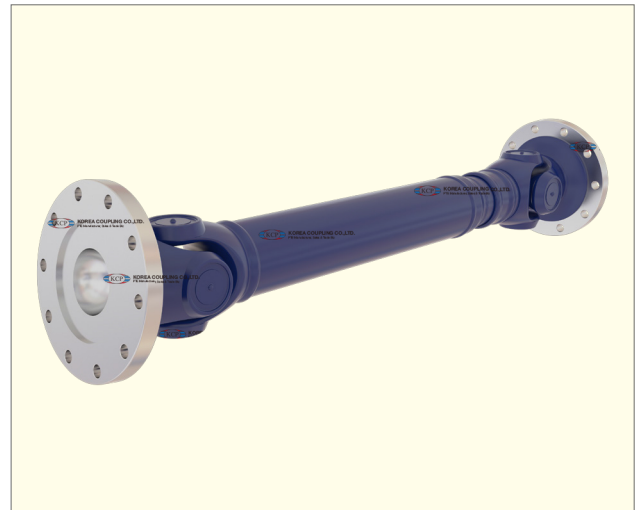

KTL Type

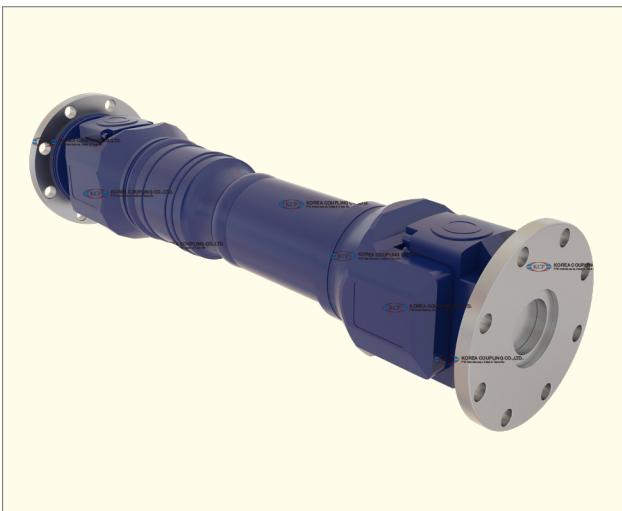

KTKL Type

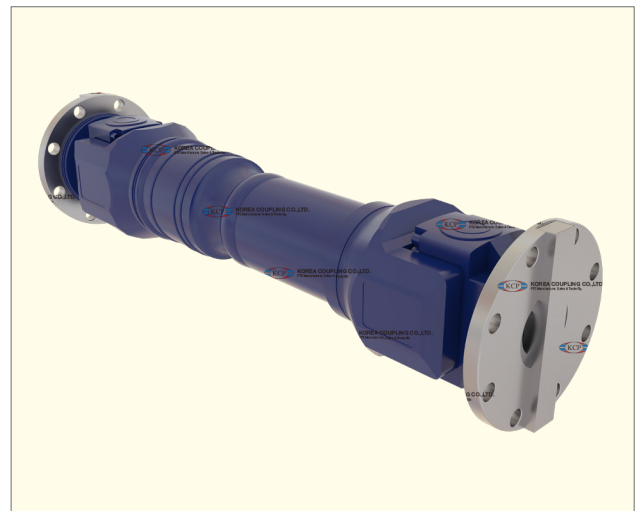

KTKS Type

KL & KLD Type

KL Type (Single)

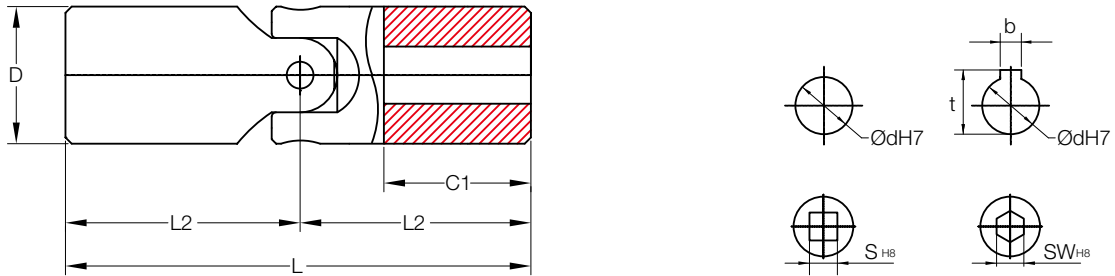

KLD Type (Double)

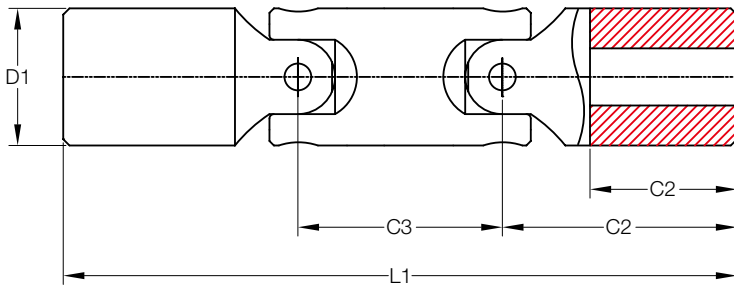

KL Type Single Size	KLD Type Double Size	Dimensions (Millimeters)										
		dH7	D	D1	L	L1	C1	C2	C3	S	SW	BXT
100	-	5	10	-	40	-	13	-	-	-	-	-
101	-	6	13	-	40	-	13	-	-	6	-	-
102	-	8	16	-	40	-	10	-	-	8	-	2 x 9
103	-	10	20	-	62	-	19	-	-	10	10	3 x 11.4
104	104	12	25	25	74	86	23	19	33	12	12	4 x 13.8
105	105	14	29	25	74	95	23	21	33	14	14	5 x 16.3
106	106	16	32	32	86	104	26	21	35	16	16	5 x 18.3
107	107	18	37	37	120	180	41	54	39	18	18	6 x 20.8
108	108	20	40	40	108	128	32	21	46	20	20	6 x 22.8
109	109	22	47	47	130	200	41	54	46	22	-	6 x 24.8
110	110	25	50	50	132	163	41	25	59	25	25	8 x 28.3
111	111	30	58	58	166	182	52	30	66	30	30	8 x 33.8
112	112	35	70	70	140/200	212/310	35/65	30/79	78			
113	113	40	80	80	160/228	245/350	42/76	38/90	95			
114	114	50	95	95	190/270	290/426	54/94	50/118	120			

* Coupling Weight is without Bore Machining

KLS Type

Spindle

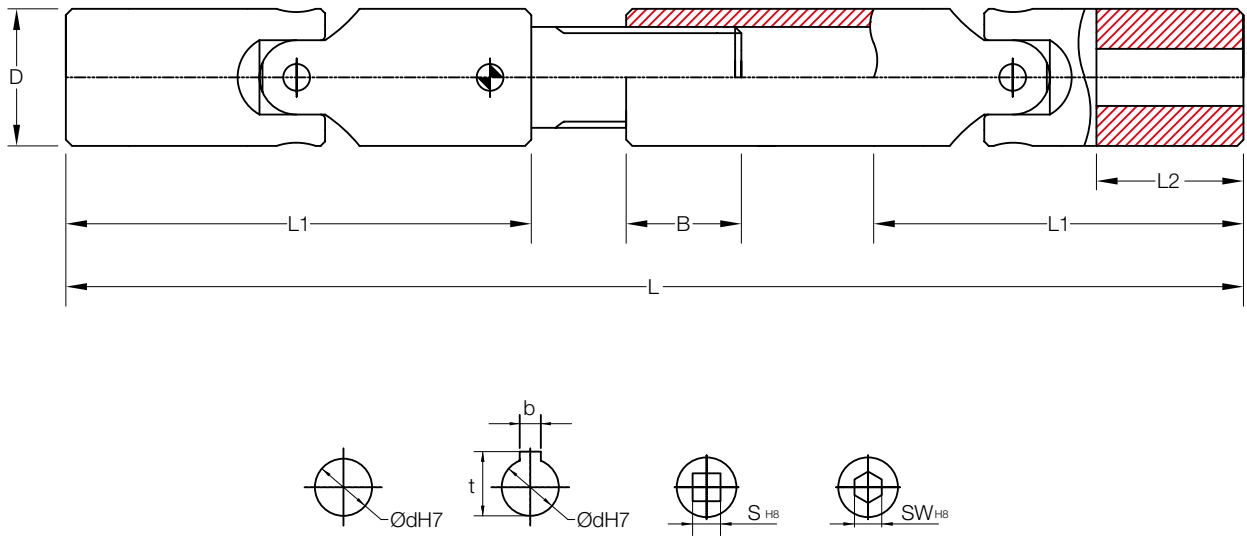

Size	Dimensions (Millimeters)							
	dH7	D	L1	L2	B	S	SW	BXT
203	10	22	45	10	40	10	10	3 x 11.4
204	12	25	50	11	45	12	12	4 x 13.8
205	14	29	56	13	48	14	14	5 x 16.3
206	16	32	65	15	50	16	16	5 x 18.3
207	18	37	72	17	51	18	18	6 x 20.8
208	20	40	82	19	56	20	20	6 x 22.8
209	22	47	95	22	60	22	22	6 x 24.8
210	25	50	108	27	69	25	25	8 x 28.3
211	30	58	122	30	70	30	30	8 x 33.8
212	35	70	140	35	70	35	35	10 x 38.3
213	40	80	160	42	75	40	40	12 x 43.3
214	50	95	190	54	80	50	50	14 x 53.8

* Coupling Weight is without Bore Machining

KTL Type

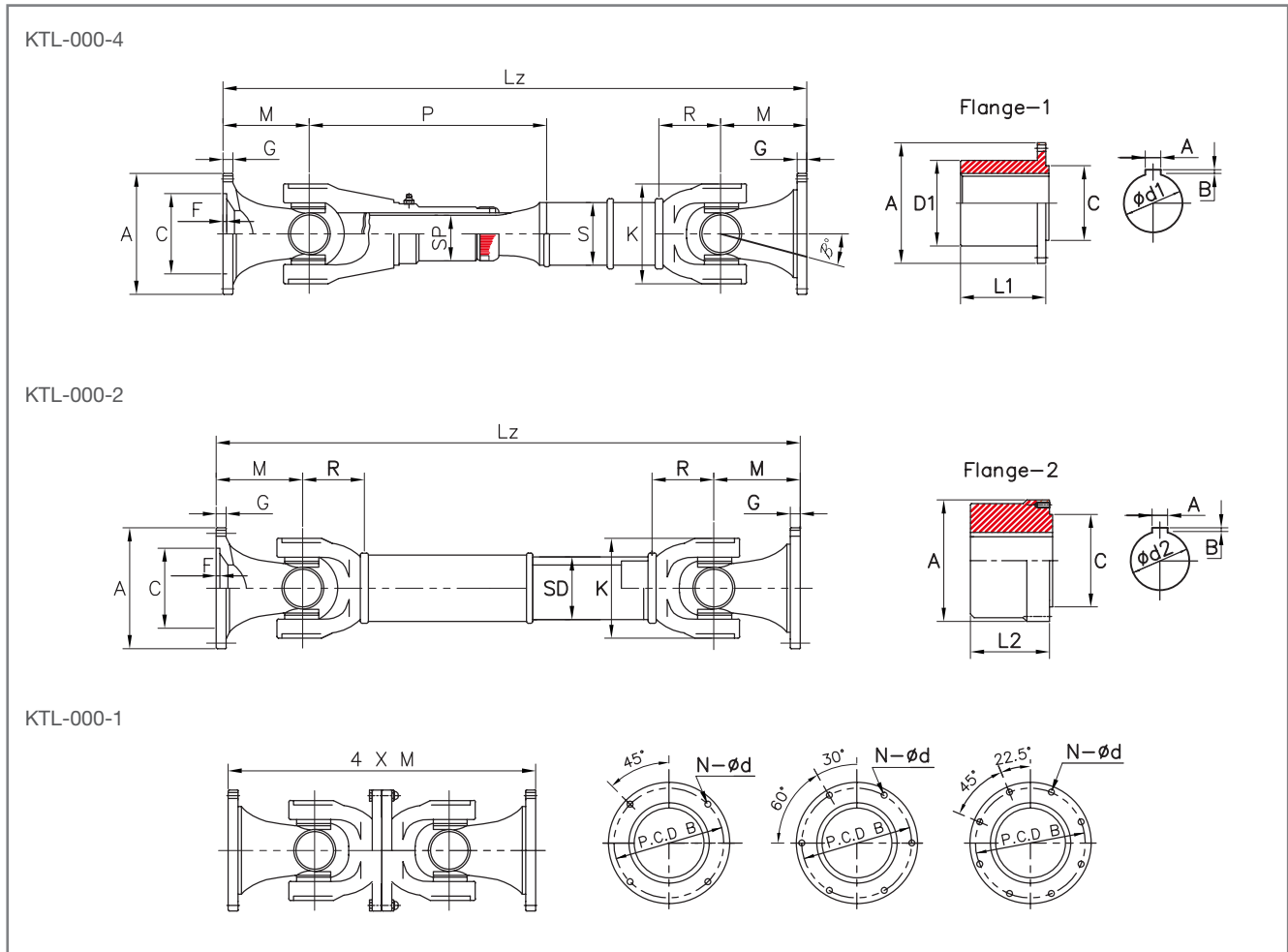

Size	Din	Torque		Angle B°	Dimensions (Millimeters)														Length LZ Min	Spline Stroke		Flange						Bolt Size
		TDW (Kgf.m)	TK (Kgf.m)		A	B PCD	øC H7	F	G	M	P	R	SP	ØS	ØK	N	Ød	+		-	1			2				
				ød1															øD		L1	ød2	L2					
58	373.20	11	15	30°	58	47.0	30	1.5	3.5	32.0	127	36.0	21.0	32.0	52	4	5	250	14	14	20	35	30	35	56	M5 x 14L		
65	373.20	15	25	30°	65	52.0	35	2.0	4.5	35.5	142	36.0	21.0	32.0	60	4	6	250	14	14	25	40	40	40	63	M6 x 18L		
75	273.30	40	55	30°	75	62.0	42	2.0	5.5	45.0	169	45.0	33.0	50.8	70	4	6	310	20	15	30	50	48	45	70	M6 X 20I		
90	287.00	70	90	25°	90	74.5	47	2.5	6	50.0	180	42.5	35.0	50.8	96	4	8	375	25	15	35	55	55	55	90	M8 x 25L		
100	287.10	95	125	25°	100	84.0	57	2.5	7	50.0	180	42.5	35.0	63.5	96	6	8	410	30	15	40	64	63	60	90	M8 x 25L		
120	287.20	150	185	20°	120	101.5	75	2.5	8.5	80.0	300	55.0	42.0	76.3	115	8	10	500	35	20	50	80	80	70	110	M10 x 30L		
150	287.30	350	480	20°	150	130.0	90	3.0	10	80.0	300	75.0	54.0	90.0	142	8	12	580	40	20	60	105	90	90	140	M12 x 40L		
160	287.30	350	480	20°	160	140.0	100	4.0	10	80.0	300	75.0	54.0	90.0	142	8	12	600	40	26	70	115	110	95	160	M12 x 40L		
180	287.40	520	670	22°	180	155.5	110	3.0	12	80.0	300	80.0	63.5	101.6	182	8	14	600	45	33	80	125	125	110	180	M14 x 45L		
200	287.40	520	670	22°	200	175.0	125	5.0	14	116.0	355	102.0	60.0	101.6	185	8	14	660	45	33	85	130	140	120	180	M14 x 45L		
225	287.40	900	1170	22°	225	196.0	140	5.0	15	108.0	450	115.0	82.0	120.0	205	8	16	730	50	40	100	160	160	135	220	M16 x 50L		

* Coupling Weight is without Bore Machining

KTKL Type

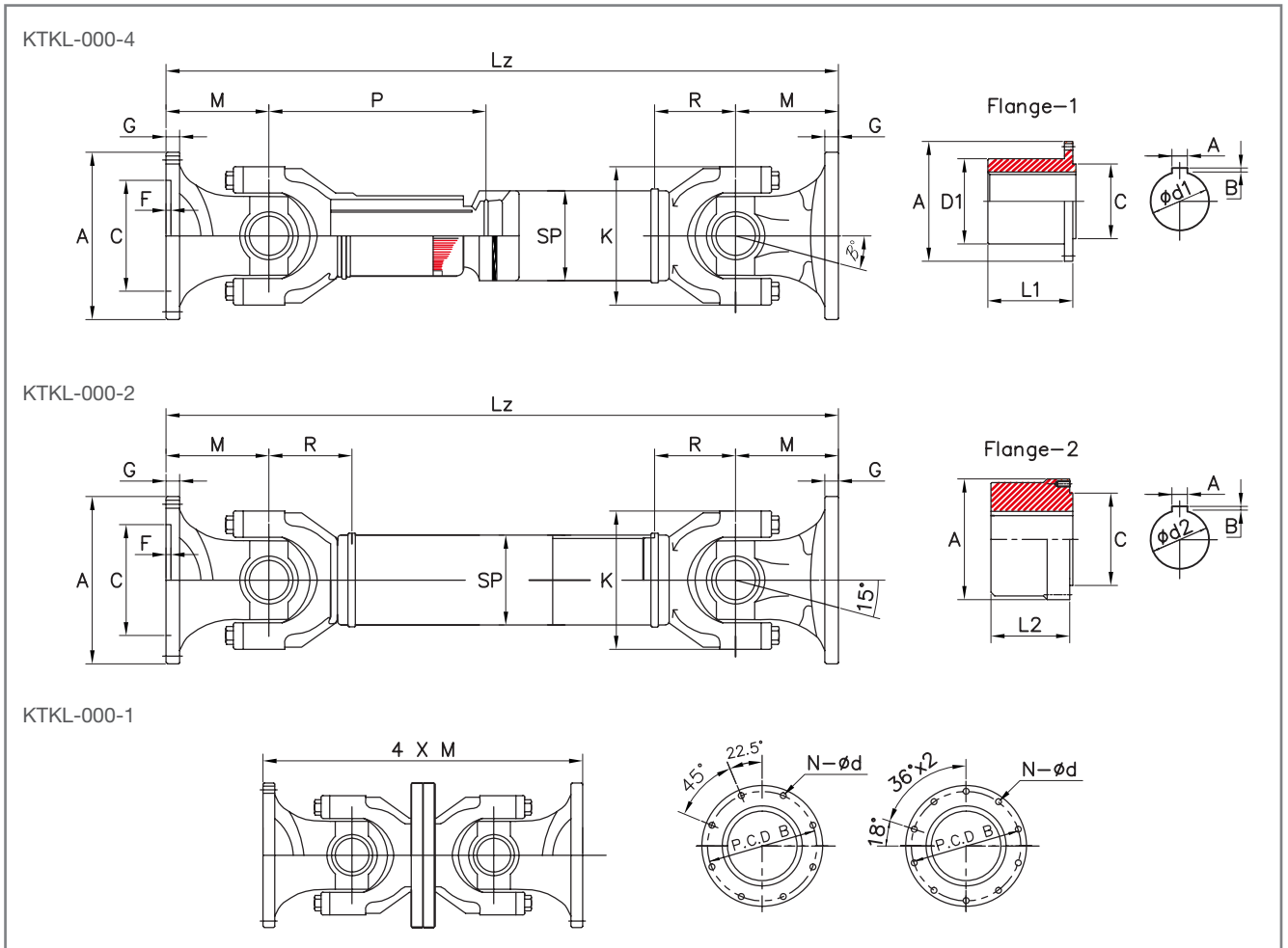

Size	Din	Torque		Angle B°	Dimensions (Millimeters)														Length LZ Min	Spline Stroke +	Flange			Bolt Size
		TDW (Kgf.m)	TK (Kgf.m)		A	B PCD	øC H7	F	G	M	P	R	SP	ØS	ØK	N	Ød	ød1			øD	L1		
200	-	1,250	1,650	15°	200	172	95	1.5	15	130	377	148	82	120	225	8	14.5	790	75	70	130	105	M5 x 14L	
225	190.50	1,250	1,800	15°	225	196	140	2.0	15	108	377	148	82	120	225	8	16.5	790	75	90	160	135	M6 x 18L	
250	190.55	1,750	2,275	15°	250	218	140	2.0	18	130	470	175	100	140	250	8	18.5	960	90	100	180	150	M6 X 20L	
285	190.60	2,650	3,700	15°	285	245	175	2.5	20	135	509	190	100	160	285	8	20.5	1,030	100	110	200	165	M8 x 25L	
315	190.65	3,750	5,200	15°	315	280	175	2.5	22	150	640	210	130	190	315	8	22.5	1,220	120	120	215	180	M8 x 25L	
350	190.70	5,350	7,200	15°	350	310	220	2.5	25	170	705	240	150	215	350	10	22.5	1,360	135	130	240	195	M10 x 30L	
390	190.75	7,300	9,400	15°	390	345	250	3.0	28	190	775	260	160	244	390	10	24.5	1,490	150	140	270	210	M12 x 40L	
435	190.80	10,000	13,600	15°	435	385	280	4.0	32	210	840	280	180	267	435	10	27.5	1,620	170	150	300	225	M12 x 40L	

* Coupling Weight is without Bore Machining

KTKS Type

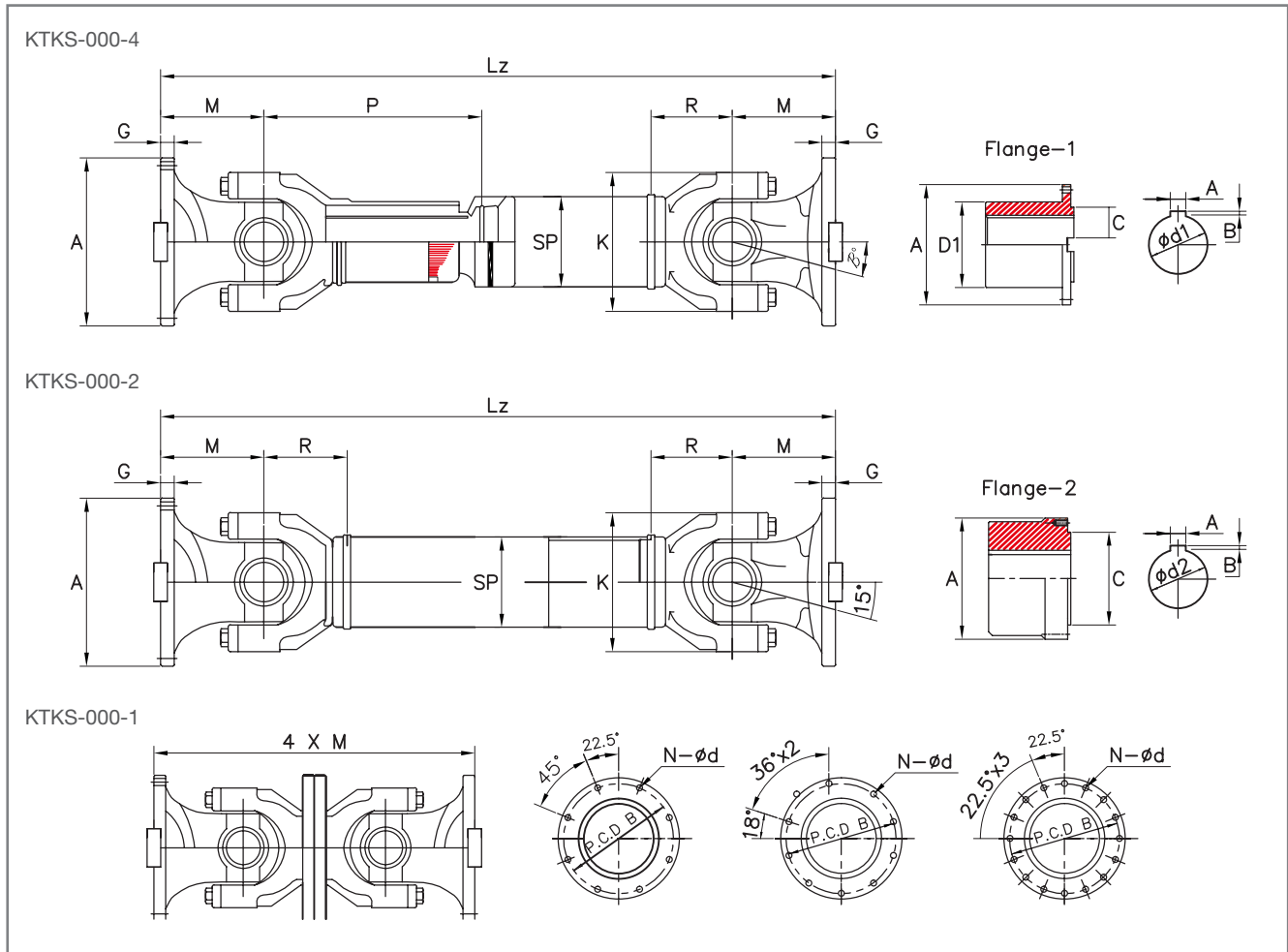

Size	Din	Torque		Angle	Dimensions (Millimeters)																Length	Spline Stroke	Flange			Bolt Size
		TDW (Kgf.m)	TK (Kgf.m)	B°	A	B PCD	φC H7	F	G	M	P	R	SP	ØS	ØK	N	Ød	X	Y	LZ Min			+	ød1	øD	
200	-	1,850	2,405	10°	200	172	95	5	20	135	420	160	100	140.0	200	8	15.5	40	10.0	850	80	70	130	105	M16 x 60L	
225	192.50	1,850	4,400	10°	215	196	105	5	20	135	475	175	100	152.0	225	8	17.5	32	9.0	965	85	90	160	135	M16 x 60L	
250	192.55	2,600	3,380	10°	250	218	105	6	25	135	590	190	100	170.0	250	8	19.5	40	12.5	1,035	90	100	180	150	M18 X 75L	
285	192.60	3,800	4,940	10°	285	245	125	7	27	150	610	210	130	200.0	285	8	20.0	40	15.0	1,180	120	110	200	165	M20 x 80L	
315	192.65	5,500	7,150	10°	315	280	130	7	32	170	740	240	150	230.0	315	10	22.0	40	15.0	1,375	135	120	215	180	M22 x 90L	
350	192.70	8,000	10,400	10°	350	310	155	8	35	185	760	260	170	245.0	350	10	22.0	50	16.0	1,485	150	130	240	195	M22 x 100L	
390	192.75	11,000	14,300	10°	390	345	170	8	40	205	880	280	170	273.0	390	10	24.0	70	18.0	1,620	150	140	270	210	M24 x 110L	
435	192.80	15,000	19,500	10°	435	385	190	10	42	235	930	330	209	318.0	435	10	27.0	80	20.0	1,795	170	150	300	225	M27 x 120L	
480	192.85	20,000	26,000	10°	480	425	205	12	47	265	1,035	305	209	355.6	480	16	31.5	90	22.5	1,950	190	165	365	250	M30 x 130L	
550	192.90	28,000	36,400	10°	550	492	250	12	50	290	1,110	350	240	406.4	550	16	31.5	100	22.5	2,120	210	220	430	330	M30 x 135L	

* Coupling Weight is without Bore Machining

Reference

Torque Comparison Table for Various Type of Couplings

Torque	Taper Grid Cplg		Gear Cplg				Disc Flexible Cplg		Max Dynamic Cplg		Tire Cplg		KW-Flex Cplg	
	T-Type (Size)	Torque (Nm)	G-Type (Size)	Torque (Nm)	SS & CC Type (Size)	Torque (Nm)	K71-Type (Size)	Torque (Nm)	KD-Type (Size)	Torque (Nm)	KCS-Type (Size)	Torque (Nm)	KW-Type (Size)	Torque (Nm)
0									2	22	100	49		
50	1020	52							3	42	120	98		62
100	1030	149					150	4,400	4	62	140	147		130
							175	184	5	108				
200	1040	249							10	164	160	215		
									20	260	185	294		
300							225	345						
400	1050	435							30	412	220	490		316
500					112	560								
600	1060	684							40	622				520
800							300	820	50	864				
900	1070	994									265	981		
1,000			1010	1,140	125	1,050	350	1,513	60	1,412	340	1,620		1,028
					140	1,510								
2,000	1080	2,050	1015	2,350	160	2,320	375	2,179	70	2,486				2,508
							412	2,540						
3,000	1090	3,730			180	3,550								
4,000			1020	4,270			462	4,561	80	4,463	445	4,900		4,011
5,000					200	5,060								
6,000	1100	6,280					512	6,209						
7,000			1025	7,470	224	7,360								
8,000														8,011
9,000	1110	9,320			250	9,930	562	9,494	100	9,605	550	9,810		
10,000	1120	13,700	1030	12,100	280	17,200	600	10,352	120	19,221	700	19,600		15,027
	1130	19,900	1035	18,500										
20,000	1140	28,600			315	27,095								
30,000	1150	39,800	1040	30,600	355	40,000								
40,000			1045	42,000										
50,000	1160	55,900	1050	56,600	400	56,100								
70,000	1170	74,600	1055	74,000			700	76,180						
90,000			1060	90,400	450	93,200	750	94,694						
100,000	1180	103,000	1070	135,000	500	127,530								
	1190	137,000												
	1200	186,000	1080	170,000										
200,000	1210	249,000	1090	226,000	560	204,000								
300,000	1220	336,000	1100	310,000	630	910,000								
400,000	1230	435,000	1120	413,000	710	450,000								
500,000	1240	559,000	1130	555,000										
600,000					800	643,500								
700,000	1250	746,000	1140	719,000										
900,000	1260	932,000	1150	911,000	900	916,300								
1,000,000			1160	1,100,000	1000	1,255,700								
			1170	1,310,000	1120	1,765,800								
			1180	1,660,000										
2,000,000			1190	2,140,000	1250	2,452,500								
			1200	2,720,000										



KOREA COUPLING CO., LTD.
PTE Manufacturer, Sales & Trade Biz

H.Q & Factory

KOREA COUPLING CO., LTD.

91-22 Songma-ro, Daegod-myeon, Gimpo-si,
Gyeonggi-do. 10027, Republic of Korea

Tel : +82 31 981 1926 (Rep)

Fax : +82 31 981 1928

E-mail : sales@koreacoupling.co.kr

Web : www.koreacoupling.co.kr

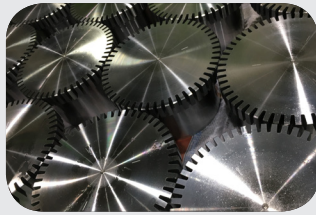

Representative in North America

Representative in Taiwan

DRIVE COMPONENTS., LLC

6519 Eastland Road, STE 106, Brookpark,
Ohio. 44142, U.S.A

Tel : +1440 234 6200
Fax : +1 440 234 1200
E-mail : sales@drivecomponentsllc.com
Web : www.drivecomponentsllc.com

TAIPEI CITY TRADING CO., LTD.

No. 4 Lane 299, Cheng Teh Road, Sec. 3,
Taipei, Taiwan

Tel : +886 2 2585 9113
Fax : +886 2 2585 7000
E-mail : C35697@ms32.hinet.net
Web : www.tpc-trading.com.tw



INNOBIZ
INNOBIZCOMPANY



Ver. 2017-04(8) ISO-9001

www.koreacoupling.co.kr



KOREA COUPLING CO., LTD.
PTE Manufacturer, Sales & Trade Biz

H.Q & Factory

91-22 Songma-Ro, Daegod-Myeon, Gimpo-Si,
Gyeonggi-Do. 10027, Republic of Korea

Tel. +82 31 981 1926 (Rep.)

Fax. +82 31 981 1928

E-mail. sales@koreacoupling.co.kr